

Royal Vendors, Inc.

# GIII

Operation and Service Manual

**230 VAC 50 Hz Models with KO Programming**



Manufactured by



Royal Vendors, Inc. • 426 Industrial Boulevard • Kearneysville WV 25430-2776 • USA  
Telephone +1 304 728 7056 • Fax +1 304 725 4016 • [technicalinquiry@royalvendors.com](mailto:technicalinquiry@royalvendors.com) • [parts@royalvendors.com](mailto:parts@royalvendors.com) • [www.royalvendors.com](http://www.royalvendors.com)



**Royal Vendors, Inc. • 426 Industrial Boulevard • Kearneysville WV 25430-2776 • USA**  
Customer Service: +1 304 728 7056 or Toll Free (*in North America only*) 1 800 931 9214 • Fax +1 304 725 4016

**E-mail:** [technicalinquiry@royalvendors.com](mailto:technicalinquiry@royalvendors.com)  
[parts@royalvendors.com](mailto:parts@royalvendors.com)

**Website:** [www.royalvendors.com](http://www.royalvendors.com)

# TABLE OF CONTENTS

---

<b>SAFETY SEGMENT</b> .....	<b>5</b>
<b>SECTION 1: General Information</b> .....	<b>7</b>
Introduction .....	7
Specifications .....	7
Unpacking the Vender .....	7
Capacity.....	7
Vender Identification .....	8
<b>SECTION 2: Set-Up and Installation</b> .....	<b>9</b>
Modes of Operation .....	9
Peripherals .....	10
Moving and Securing the Vender .....	10
Loading the Vender .....	11
Using the HHC to Program The Vender .....	14
Testing the Vender .....	14
Installing the Vender on Location .....	14
Four-Button Programming.....	15
KO Programming Flowchart.....	16
EMS Software.....	17
Internal (Service) Menu .....	17
Error Display Mode (Error) .....	17
Coin Payout Mode (CPO).....	19
Tube / Stack Fill Mode (tUFL).....	19
Recycler Pay Out (rPO).....	19
Test Vend Mode (tEst) .....	20
Password Protection (PASS).....	21
Cash Counter Display Mode (CASH) .....	21
Vend Counter Display Mode (SALE) .....	21
Card Counter Display Mode (CArd) .....	21
Token Counter Display Mode (toKn) .....	22
Free Vend Accounting Mode (FrEE).....	22
Selection Price Setting Mode (PrIC).....	23
Space-to-Sales Programming Mode (StS) .....	23
Machine Configuration Mode (Con) .....	24
Correct Change Only Control Mode (CCOC) .....	26
Preview Data Password Mode (PrEU) .....	26
Language Selection Mode (LAnG) .....	27
Time/Date Setting Mode (tinE) .....	27
Lighting Control Mode (Lit).....	29
Refrigeration Control Mode (rFrG) .....	31
Block Selection 1 and 2 (bLCI & bLC2).....	33
Discount Setting (dISC).....	35
Manual Switch Over-Ride (OUEr) .....	36
Set Selection Depth Mode (SdEP).....	38
Remote Vend Mechanism Routine (rUnd).....	38

# TABLE OF CONTENTS (continued)

---

Return To Sales Mode (rtn) .....	39
External Menu .....	40
Vend Counter Display Mode (SALE) .....	40
Cash Counter Display Mode (CASH) .....	40
Error Display Mode (Error) .....	40
Return to Sales Mode (rtn) .....	40
<b>SECTION 3: Vender Component Explanation .....</b>	<b>41</b>
Vender Controller .....	41
Digital Display .....	41
Door Switch .....	42
Delivery Chute Sensor .....	42
Low Voltage Transformer .....	42
Selection Switches .....	42
Coin Changer .....	42
Banknote Acceptor .....	42
Debit Card Reader .....	42
Vend Rack Assembly.....	43
Vend Rack Components.....	43
Refrigeration System.....	45
The Electronic Refrigeration Cycle.....	46
<b>SECTION 4: Vend Sequence of Operation .....</b>	<b>47</b>
Vend Sequence .....	47
Column Sequencing .....	48
Sold Out.....	48
<b>SECTION 5: Maintenance .....</b>	<b>49</b>
Interconnect Drawing .....	49
Controller Board Layout .....	50
Taking Care of the Vender .....	51
Removal of Vender Components .....	52
Troubleshooting .....	57
Refrigeration Flow Chart .....	67
<b>SECTION 6: Optional Equipment .....</b>	<b>68</b>
<b>SECTION 7: Exploded Views .....</b>	<b>69</b>

# SAFETY SEGMENT

---

## ROYAL VENDORS' COMMITMENT TO SAFETY

Royal Vendors is committed to safety with all of our product designs. We are committed to notifying the user of a possible danger involving the improper handling or maintenance of our venders. The servicing of any electrical or mechanical device involves **potential dangers**, both to those servicing the equipment and to users of the equipment. These dangers can occur because of improper maintenance or usage. The purpose of this safety segment is to alert everyone servicing Royal equipment of potentially dangerous areas, and to provide **basic safety guidelines** for proper upkeep.

The service manual contains various **warnings** that should be carefully read to minimise the risk of personal injury. This manual also contains service information to insure that proper methods are followed to avoid damaging the vender or making it unsafe. It is also important to understand these **warnings** provide general guidance only. Royal could not possibly know, evaluate, or advise of all of the conceivable ways in which service might be done. Consequently, Royal cannot predict all of the possible dangerous results. These outlined safety precautions are the basis for an effective safety program. Use these safety measures, along with the service bulletins, helpful hints and product specification sheets, when installing or servicing Royal equipment.

We recommend that persons servicing our equipment maintain a similar commitment to safety. **Only personnel properly trained should have access to the interior of the vender.** This will minimise the potential dangers that are inherent in electrical and mechanical devices. Royal has no control over the vender once it leaves the premises. It is the owner or lessor's responsibility to maintain the vender in a safe condition. See installation insert located in the coin box of a new vender for proper installation procedures and refer to the service manual for recommended maintenance procedures. If you have any questions, please contact the Technical Service Department at +1 304 728 7056.

## SAFETY REGULATIONS

- Read the safety segment before installation or service.
- Test for proper earthing before installing to reduce the risk of electrical shock and fire.
- Turn off or disconnect power cord from power source before servicing.
- Only fully trained service technicians should service vender when vender has power.
- Remove any product before moving a vender.
- Use appropriate equipment when moving a vender.
- Always wear eye protection, and protect your hands, face, and body when working near the refrigeration system.
- Use only authorised replacement parts.
- Be aware of inherent dangers in rocking or tipping a vender.

## SECTION I: ELECTRICAL HAZARDS GENERAL ADVICE

Careless or improper handling of electrical circuits can result in injury or death. Anyone installing, repairing, loading, opening, or otherwise servicing a vender should be aware of this precaution. Apply all of the normal precautions when handling electrical circuits, such as:

- Refrigeration servicing to be performed by qualified personnel only.
- Unplug the vender before servicing.
- Replace electrical cords if there is any evidence of fraying or other damage.
- Keep all protective covers and earthing wires in place.
- Plug equipment into outlets that are properly earthed and polarised (where applicable), and protected with fuses or circuit breakers of the correct size.
- All electrical connections must be dry and free of moisture before applying power.

***WARNING: ALWAYS TEST TO VERIFY PROPER EARTHING PRIOR TO INSTALLATION IN ORDER TO REDUCE THE RISK OF ELECTRICAL SHOCK AND FIRE.***

# SAFETY SEGMENT

---

## SECTION II: ELECTRICAL HAZARDS

### A. Servicing with Power Off

For maximum safety, unplug the power cord from the wall outlet before opening the vender door. This will remove power from the equipment and avoid electrical hazards. Service personnel should remain aware of possible hazards from hot components although electrical power is off.

### B. Servicing with Power On

Some service situations may require access with power on. Only fully qualified service technicians should perform power-on servicing. Particular caution is required in servicing assemblies that combine electrical power and mechanical movement. Sudden movement (to escape mechanical action) can result in contact with live circuits and vice versa. It is therefore important to maintain maximum clearances from both moving parts and live circuits when servicing.

### WARNINGS:

- 1. ONLY FULLY TRAINED PERSONNEL SHOULD ACCOMPLISH SERVICING WITH POWER ON. SUCH SERVICE BY UNQUALIFIED INDIVIDUALS CAN BE DANGEROUS.**
2. LIGHTING CIRCUITS CAN BE HAZARDOUS. ALWAYS DISCONNECT FROM POWER SUPPLY BEFORE REPLACING A BULB OR SERVICING THE VENDER IN THAT AREA.
3. NEVER USE A HOSE, PRESSURE WASHER OR ANY CLEANING METHOD THAT COULD WET ELECTRICAL COMPONENTS. SEE CLEANING SECTION OF MANUAL FOR SUGGESTED CLEANING METHODS. IF WATER CONTAMINATION OF ELECTRICAL COMPONENTS IS SUSPECTED, USE QUALIFIED ELECTRICAL TESTING EQUIPMENT AND TEST METHODS TO ASSURE THAT VENDER IS NOT A HAZARD BEFORE APPLYING POWER FOR ANY REASON.
4. **CAUTION:** REMOVE POWER TO THE VENDER BEFORE ATTEMPTING ANY SERVICE INVOLVING THE CHAIN, VEND MOTOR, OR LEVERS. **HAZARD:** THE VEND CHAIN IS CONTROLLED BY A LOW-VOLTAGE, LOW-ENERGY MOTOR. THE VEND CHAIN MAY BE ACTIVE WHEN THE DOOR SWITCH IS PUSHED INTO THE CLOSED POSITION, THE “tESt” MODE IS USED IN PROGRAMMING, OR AN ACTUAL VEND IS MADE. NEVER PLACE HANDS INTO THE DRIVE MECHANISM WHILE THE VENDER IS ENERGISED. A PAINFUL PINCH IS POSSIBLE, WHICH MAY RESULT IN CUTS OR BRUISES.

# SECTION 1: GENERAL INFORMATION

## Introduction

This manual contains installation, operation and service instructions for Royal Vendors' G-III All-Purpose Vender. This manual also contains a complete parts catalogue and electrical wiring diagram for the G-III vender.

The G-III is a microprocessor controlled vender which permits pricing per selection from 0.00 to 99.99. The G-III vender provides electronic space-to-sales (STS) programmability and will collect, store and transfer MIS data fields to a hand-held computer (HHC) or online device.

## Specifications

Dimensions ... (804 cap.) 202 cm H x 94 cm W x 86 cm D  
(660 cap.) 183 cm H x 94 cm W x 86 cm D  
Approximate Empty Weight ..... Wide (804) 296 kg  
Wide (660) 272 kg  
Narrow (550) 243 kg  
Capacity ..... (804 cap.) 355 mL cans, 12 columns  
(660 cap.) 355 mL cans, 12 columns  
Operating Voltage ..... 230 VAC, 50 Hertz  
Amperage Rating ..... 5.5 AMP  
Charge ..... 0.17 kg R134A  
Construction ..... Steel cabinet, steel rack  
Selections ..... 9 or 13 selections  
Altitude Adjustment ..... no adjustment required  
for the GIII's Electronic  
Cold Control

## Unpacking the Vender

### Unwrap the Vender

Unwrap the vender and remove the padding. Check for any signs of damage. If the vender is damaged, contact the carrier straight away. They will instruct you as to the procedure for filing a claim.

*NOTE:* The vender keys are located in the coin cup.

### Remove the Shipping Skid

Separate (split) each section by inserting either a claw hammer, crowbar or similar device into the slot of each section to break apart. Tilt the vender slightly to remove the separated pieces (see Figure 1.1).

## Capacity

PACKAGE TYPE	804 MODEL	660 MODEL
600 mL Plastic Coke Contour Bottle	360	288
600 mL Plastic Sprite Contour Bottle	360	288
600 mL Plastic Surge/Bolt Bottle	336	276
600 mL Plastic Straight Wall Bottle	336	276
500 mL Fruitopia Bottle	336	276
600 mL Plastic PowerAde Bottle	372	300
500 / 600 mL Glass Straight Wall Bottle	324	264
355 mL Can	804	660
16 oz. Can	396	324
10 oz. Bottle	384	312

*NOTE:* Since new packaging is constantly being introduced, this listing may not contain ALL vendible packages. For the latest information on packages that will vend in the GIII, please contact Royal Vendors' Customer Service Department.

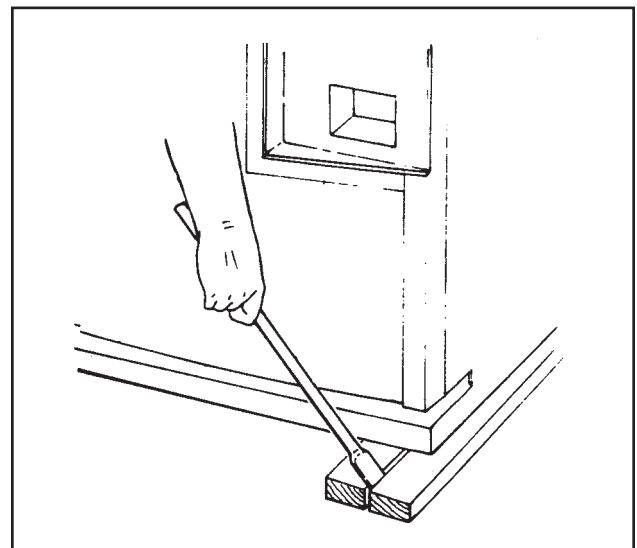

Figure 1.1

# SECTION 1: GENERAL INFORMATION

## VENDER IDENTIFICATION

Your G-III vending machine can be easily identified by taking note of the following three items:

1. Vender Serial Plate - mounted on the exterior left side of the vender's door.
2. Refrigeration Serial Plate - mounted on the "kick plate" of the refrigeration unit.
3. Control Chip Revision Number - Mounted on the upper part of the control board. Also can be read on the L.E.D., when the door is first closed.

VENDER SERIAL PLATE - The vender's main serial plate (shown in figure 1.2) is located on the exterior left side of the vender's main door and has the following information:

- Vender model number
- Vender serial number
- Amps required by vender
- Unit charge of R134A
- Refrigeration design pressures

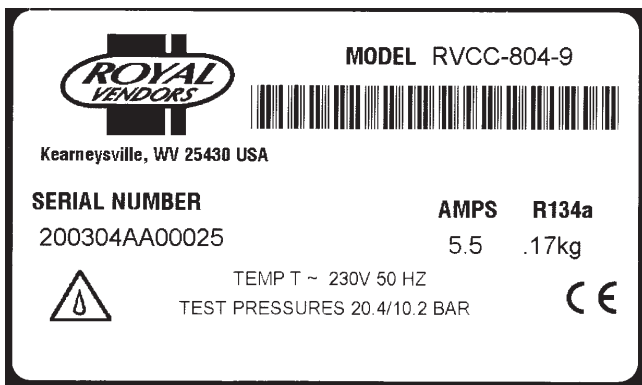

Figure 1.2

The vender's model number contains two important pieces of information: the machine type, such as RVCC (Royal Vendors Coca Cola); and the vender model number, such as 804-9 (capacity of 804 - 355 mL cans / 9 selections).

How to read the serial number:

- The first 4 numbers represent the year the vender was produced.
- The 5th and 6th numbers represent the week within the year the vender was produced.
- The 1st letter represents the style of vender.
- The 2nd letter represents the location the vender was built.
- The last five numbers represent the model built within that week.

## REFRIGERATION SERIAL PLATE

The refrigeration serial plate is located in the bottom of the vender's cabinet in front of the condenser coil and is mounted to the refrigeration unit "kick plate". It looks similar to the serial plate shown in figure 1.2, with the exception that the model number specified is the refrigeration unit model (as shown below). There is currently one model in use:

**Model - 8000**

**Compressor Size - Super 1/3 Horsepower**



## SECTION 2: SET-UP AND INSTALLATION

### Modes of Operation

The G-III vender operates in three basic modes: Sales Mode, Open-Door Mode, and Service Mode.

#### Sales Mode

This is the normal mode of operation when the vender's door is closed. This display will scroll one of these messages unless credit is present:

- 1) The point-of-sales (P.O.S.) greeting;
- 2) "SOLd Out," if the controller detects that all selection columns have been sold out or if there is a vend problem; or
- 3) "NO SALE til," if all valid selections are included in the lockout range and one of the lockout time ranges is active. (See "bLC1" or "bLC2" of this manual for a description of setting selection lockout ranges.)

**Note:** 67121-1 & -2 chips will show "SOLd Out".

If the "SOLd Out" message is displayed, the "SOLD Out" LED will also be flashing.

If the Free Vend Switch is on, the "FrEE" message will be displayed immediately after the P.O.S. greeting. This works in conjunction with the override.

If the machine is set for single-price mode (see "CON" section of this manual), the vend price will be displayed immediately after the greeting.

**NOTE:** Prices displayed in the Sales Mode will be rounded up to the next multiple of the lowest scale factor. For example, if prices are set to 0.50 with a coin changer and banknote acceptor present, and the system is powered up at a later time with the changer removed and prices have not been changed, the prices will display in the sales mode as 1.00, while they will still be 0.50 in the Service Mode.

If the P.O.S. greeting is being displayed and the temperature display option has been set in the Service Mode, this message would be displayed after the P.O.S. greeting.

If the vender is in a lockout condition, "No SALE tIL XXXX" will replace the P.O.S. greeting. Where "XXXX" represents the time the selections will come on. If dSP in the rFrG Mode is set to "1", the temperature will also be displayed after the lockout message.

The "USE CORRECT CHANGE" LED will be lit when the five-cent tube is empty or if there is less than twenty cents in the five-cent and ten-cent tubes, or the total tube cash is less than the difference between the maximum and minimum vend price plus twenty cents.

If any column has been detected as sold-out or jammed, the rightmost decimal point on the LED display will be



continuously lit.

If credit has been established, that amount of credit will be displayed instead of the above messages in the single price configuration setting. When a token has been accepted, "FrEE" will be displayed. If no activity is sensed for a period of five minutes, all credit will be cleared, any banknote in the escrow will be returned, and any card in the card reader will be returned (provided that C7 is set to 0).

If a lockout range begins and all valid selections are included in the lockout, any existing credit will be returned to the customer straight away.

External Preview Mode allows you to access error codes, cash, sales totals, and software version without opening the vender door. This mode is entered after a user-changeable four-digit password is entered. See "PrEU" section of this manual for instruction on changing this password.

#### Open-Door Mode

When the vendor door is opened, the vender enters the Open-Door Mode and begins displaying any existing errors, or "nonE" if no errors exist. See "Error" section of this manual for a description of all errors.

If configuration option C4 (see "Con" section of this manual) is enabled (set to "1"), the total machine sales and total machine cash values are displayed before the error codes. These values are displayed the same as in the "SALE" and "CASH" service mode functions (see the "SALE" and "CASH" sections of this manual).

While in the Open-Door Mode, pressing the Service Mode Button will put the vender into the Service Mode. Any other input (selection switch, escrow lever, credit input) will revert the vender to Sales Mode, even though the door is open.

#### Service Mode

All programming of vender options is done in the Service Mode. This mode is entered by pressing the Service Mode Button while the vender door is open, at which time "Error" will be displayed (see "Four-Button Programming" section of this manual for further programming instructions).

## SECTION 2: SET-UP AND INSTALLATION

---

### Peripherals

The G-III Vender with Four-Button Programming can utilise three different credit acceptance devices (MDB only): the coin changer, the banknote acceptor, and the debit card reader. One of these devices can be used alone or all three can be used together on some venders. Unlike many venders, it is not necessary to have a coin changer installed for the G-III Vender to function. For example, the G-III can function using a banknote acceptor only. In this configuration, all prices are rounded up to the nearest banknote amount, and the customer receives no change.

**CAUTION:** *Whenever possible, do not plug or unplug peripherals while power is applied.*

### Coin Changer Installation

The coin changer mounts to a panel located on the inside of the vender's main outer door. The panel contains three mounting screws which are used to mount and secure the coin changer in the vender. Install the coin changer into the vender as follows:

1. Remove the acceptor from the changer, set the key holes in the back of the changer housing over the mounting screws in the vender. Tighten snugly.
2. Set the coin changer option switches to the desired settings. (See separate coin changer literature for detailed information.)
3. Replace acceptor and connect the coin changer power plug to the mating connector from the vender controller.
4. Load coin tubes using the Tube Fill Mode of the Service Mode. **NOTE:** *If Tube Fill Mode is not used to load the tubes, cash accountability figures will be approximate, not exact.*
5. Test changer with a variety of coins to ensure proper operation.

**NOTE:** *For detailed changer information, refer to separate operation and service manual for coin changer.*

### Banknote Acceptor Installation

The banknote acceptor / debit card reader mounting hole is located on the inside of the vender outer door. Remove the filler plate by removing the four nuts which secure the filler plate, remove the filler plate and store it for future use (in the event the banknote acceptor is removed). Install the new mounting plate in accordance with banknote acceptor / debit card reader mounting instructions provided with the banknote acceptor unit and its respective mounting plate.

### Debit Card Reader Installation:

Contact the Royal Vendors Service Department at +1 304 728-7056 for proper instructions.

### Connecting the Multi-Drop Bus Interface Harness:

1. Make sure MDB harness provided with banknote acceptor / card reader is already connected to the banknote acceptor / card reader.
2. If utilising a coin changer, unplug the coin changer connector.
3. Plug the Y-harness mating connectors of the banknote acceptor / card reader to the coin changer (if applicable) and the vender's MDB harnesses.

### Moving and Securing the Vender

**The GIII vender weighs over 350 kg. Be very careful when moving the vender, and move it only with approved equipment. NEVER move the vender with product loaded inside.**

**Once the vender has been placed on location, it is recommended that it be secured to prevent rocking or tipping. Because of the vender's weight, rocking or tipping the vender could cause bodily injury or even death.**

# SECTION 2: SET-UP AND INSTALLATION

## Loading the Vender

See “Capacity” section for exact G-III capacity figures for each vendible package. Any G-III column is capable of vending a variety of packages.

### Resetting a Column / Setting Up a Column For the First Time

#### 1. Set Front and Rear Retainer Positions (For Package Length).

See Figures 2.1 or 2.2 for proper positions for each package type. See “Setting the front and rear retainers” section for more information.

#### 2. Adjust Product Stops (For Package Diameter).

See “Setting the Long and Short Adjustable Product

Stops” section for more information.

#### 3. Set Up Space-To-Sales.

See “Space-to-Sales” section for selecting an option.

#### 4. Configure Depth Setting For Each Selection.

Configure “SdEP” based on package to be vended (single depth vs. double depth packages). See the “SdEP” section of this manual.

*Note: This setting may not be shown as a menu, if con 2 is set to “0”.*

Load the columns with the desired package type. Note that bottles must always be loaded with caps facing away from the rack centre. Can tops can be loaded either way but the last two cans in a column should always be loaded on the left side of the column.

### Venders built PO 1504 and after

Retainer and Product Stop Positions by Package Type			
PACKAGE	RETAINERS		PRODUCT STOPS
	FRONT	REAR	
20 oz. Plastic Contour	7	3	Large
20 oz. Plastic Straight Wall	8	4	Large
20 oz. Plastic Surge® / Bolt	7	3	Large
20 oz. Plastic POWERaDE®	9	5	Large
20 oz. Glass Straight Wall	7	4	Large
16 oz. Glass Fruitopia®	10	7	Large
16 oz. Glass Straight Wall	10	7	Large
16 oz. Can	9	8	Small
12 oz. Can [2 deep]	1	1	Small
10 oz. Glass Straight Wall	12	9	Small

For the latest information on GIII vendible packages, please contact Royal Vendors' Customer Service.

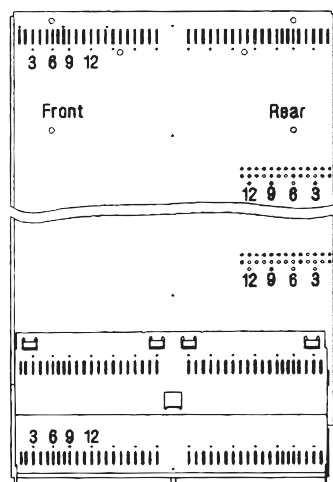

Figure 2.1

### Venders built before PO 1504

Retainer and Product Stop Positions by Package Type			
PACKAGE	RETAINERS		PRODUCT STOPS
	FRONT	REAR	
20 oz. Plastic Contour	7	3	Large
20 oz. Plastic Straight Wall	8	4	Large
20 oz. Plastic Surge® / Bolt	6	2	Large
20 oz. Plastic POWERaDE®	8	5	Large
20 oz. Glass Straight Wall	7	4	Large
16 oz. Glass Fruitopia®	9	7	Large
16 oz. Glass Straight Wall	9	7	Large
16 oz. Can	8	8	Small
12 oz. Can [2 deep]	1	1	Small
10 oz. Glass Straight Wall	12	9	Small

For the latest information on GIII vendible packages, please contact Royal Vendors' Customer Service.

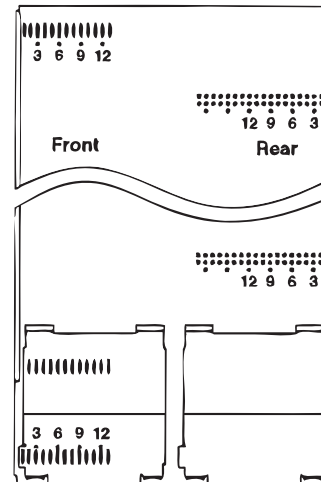

Figure 2.2

# SECTION 2: SET-UP AND INSTALLATION

## Setting the Long and Short Adjustable Product Stops (See Figures 2.3 and 2.4)

**NOTE:** If an adjustable product stop must be reconfigured, the affected column must first be emptied of product. Rear columns **must** be emptied when repositioning front column parts. It is strongly advised that front columns also be emptied even when only reconfiguring rear columns due to the potential danger of dumping a column of product.

**NOTE:** Adjusting the product stop in a front column will affect the product stops in the column to the rear. It is best to decide upon the setting for both the front and adjacent rear column before pulling the product stop rod. This allows adjustment of both at the same time.

Slide the retainer on the front of the base upwards, exposing the head of the product stop rod. Pull the rod straight out until the tip just clears the hole of the adjustable product stop to be repositioned. Reinsert the rod back into each product stop after shifting it to align the rod with the desired hole. Both adjustable product stops within a single column should always be set to the same position. After the rod is fully inserted, move the retainer down to cover the head of the rod.

**Small Package Position (right hole):** For 250 mL cans, 355 mL cans, and 500 mL bottles (smaller vend throat).

**Large Package Position (left hole):** For most other packages (larger vend throat).

Packages Against Rack  
Center & Bottle Caps Face  
Away From Rack Center

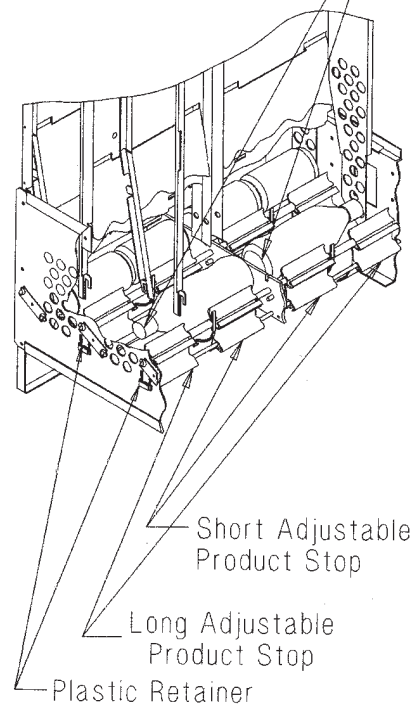

**Note:** Venders built prior to 1504 will have a plastic retainer.

Figure 2.3

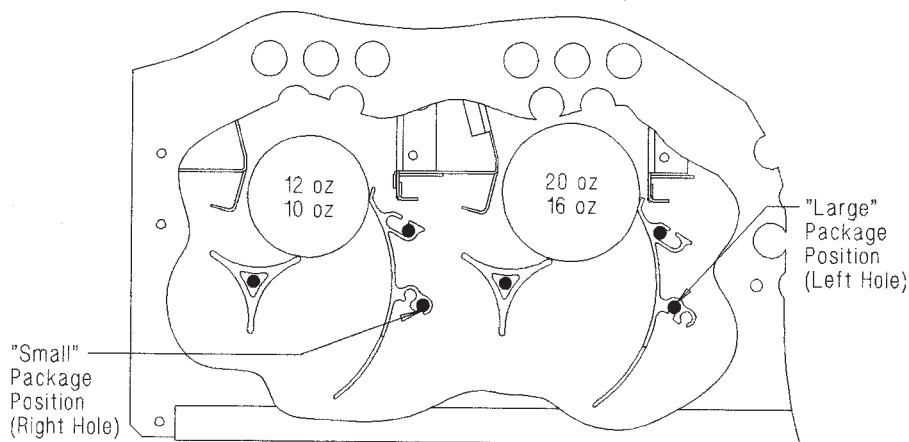

**Note:** Long & short adjustable product stops of the same column must always be set to the same position.

Figure 2.4

# SECTION 2: SET-UP AND INSTALLATION

## Setting the Adjustable Product Retainers

See Figure 2.2 for proper positions for each package type.

*NOTE: Since new packages are constantly being introduced, the listing in Figure 2.2 does not contain ALL vendible packages. For the latest information on packages that will vend in the G-III, please contact Royal Vendors' Customer Service department.*

### Front Retainers - Columns 1 through 6 (Figure 2.3)

**1. Determine Correct Position for Package Type (See Figure 2.2).**

Use Figure 2.2 to determine the proper position for the package type to be vended.

**2. Determine if Retainer is Already in Proper Position.**

Check the current position of the front retainer. Note that slots are counted from front to rear of the vender; i.e. retainer position 3 would be the third slot from the front of the machine. "Counting holes" located beneath every third slot will aid in positioning. If retainer is already in the correct position, go to Step 4.

**3. Reposition Front Retainer (if necessary).**

Lift the front retainer upwards, pivoting the upper portion out and away from the column wall. This will allow the front retainer to be lifted further in order to disengage the lower hook. Re-install the retainer, reversing the removal procedure. Make sure hooks are in aligned slots at both the top and bottom.

**4. Repeat for Column's Other Front Retainer.**

Adjust the column's other retainer, making sure it is located in the same number slot.

### Rear Retainers - Columns 7 through 12

**1. Determine Correct Position for Package Type (See Figure 2.2).**

Check Figure 2.2 for the correct retainer position.

**2. Determine if Retainer is Already in Proper Position.**

Check the current position of the rear retainer. Note that holes are counted from the rear forward; i.e. retainer position 5 would be the fifth hole from the rear of the machine. The lower row of "counting holes" located beneath every third hole will aid in positioning the rear retainers. If retainer is already in the correct position, skip Step 3.

**3. Reposition Rear Retainer.**

Relocate rear retainer by depressing the upper and lower set of locking tabs. When re-installing in

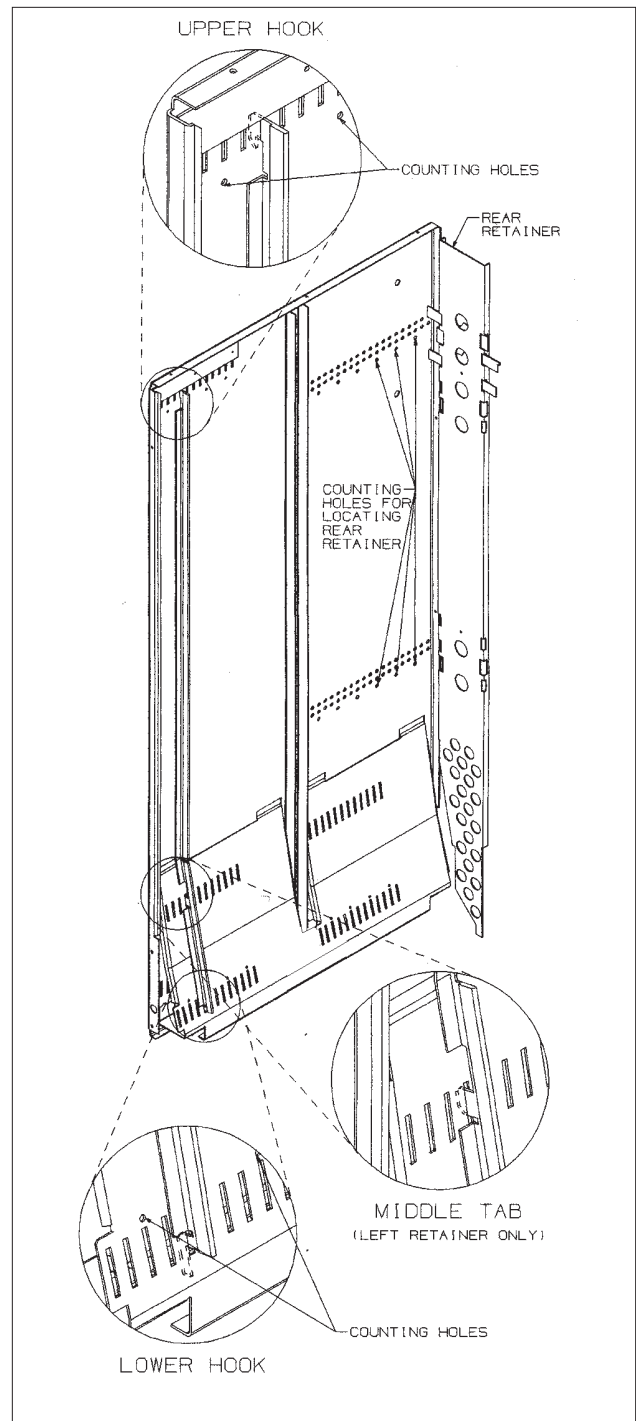

Figure 2.5

proper position, make sure locking tabs are in same position (aligned holes) on left and right walls, as well as the upper and lower hole positions.

## SECTION 2: SET-UP AND INSTALLATION

### Using the Hand-Held Computer (HHC) to Program The Vender

The G-III Vender interfaces with Direct Exchange/Uniform Communication Standard (DEX/UCS) or DEX/UCS Compatible Hand-held Computers (HHC). The HHC may be used to program the G-III Vender's vend price and space-to-sales, as well as other pertinent MIS and security information. The HHC interfaces to the vender controller via a computer socket located on the control board. Once the HHC is connected and meets initial communication requirements, it may then be used to program the G-III Vender. See separate HHC manual for detailed programming instructions (provided by the manufacturer of the HHC).

**NOTE:** The HHC may be used to lock out the manual programming of the vender.

**CAUTION:** Connect HHC only after power has been applied to the vender. Allow "8888" message to clear from controller display before connecting HHC.

### Testing the Vender

Load coins in coin mechanism through "TuFL" mode and make sure all coins lie flat. Close the vender door and secure with door lock. Using a variety of coins and/or banknotes, check the vender operation by vending several cans and/or bottles from each column. Before putting vender into service, allow the vender to run overnight to stabilise the cabinet temperature.

**NOTE:** Install and/or adjust the select button flavour strips to correspond to the loading of the columns.

---

**It is not necessary to prime the vend columns before putting the vender into service.**

---

### Installing the Vender on Location

#### Placing the Vender on Location

When placing the vender on location, allow for a minimum of 10 cm of space at the back of the vender. This will ensure proper ventilation of the refrigeration system (see Figure 2.6).

#### Level the Vender

Level the vender by adjusting the four levelling legs on the bottom corners of the vender. Use a "bubble level" on the top and side of cabinet to ensure the vender is level. The four levelling screws must be in contact with the floor (see Figure 2.6).

#### Voltage Requirements

The vender is designed to operate at a voltage of 230 volts, 50 Hertz. It requires the minimum of a 7 amp dedicated service. The service outlet voltage must not exceed 264 VAC or fall below 198 VAC. The power supply must be earthed!

#### Vender Power Cord

The vender has a three-wire earthed power cord suitable for connection in the vender's ship-to location. The vender must be plugged into an earthed electrical outlet to protect the customer from an electrical shock. If the outlet is not equipped with an earthed socket, one should be installed by a qualified electrician.

The power cord is to be replaced only with an original Royal Vendors part. Power cord replacement is to be performed only by a service technician trained on Royal Vendors equipment. Items requiring earthing are connected to the electrical mains by green / yellow-striped wire. These wires connect to the vender's main earth. If

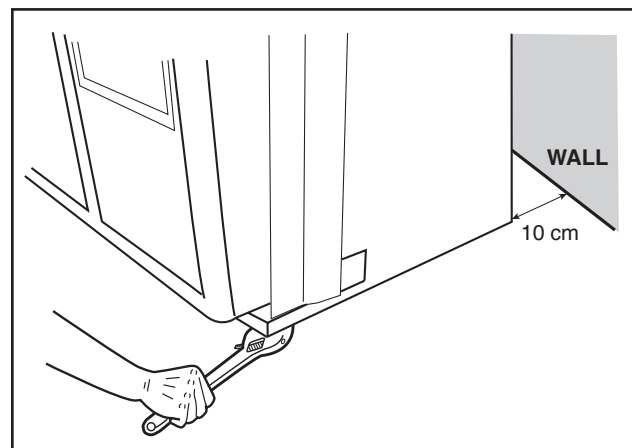

Figure 2.6

## SECTION 2: SET-UP AND INSTALLATION

an earthing wire is disturbed for service of a component, it must be secured prior to placing the vender back in service.

**NOTE:** Extension cords are not recommended unless authorised prior to use by a certified electrician.

**If you are not sure your outlet is properly earthed, have it checked by a qualified electrician.**

### SAFETY NOTES:

- Within the vender, service areas that contain line (230 VAC) voltage are marked with a black lightning bolt on a yellow background (see Figure 2.8). With the exception of the vender's main door (protected by a safety interlock switch), these areas are covered by a panel requiring a tool for removal. Only qualified service technicians should remove these panels. Panels must be reinstalled after service operations.
- The lighting system is contained within the vender's main door and is the only line-voltage equipment in the door. When the inner door is pulled away from the main door, an all-pole safety switch actuates and disconnects line voltage from the main door. A special tool is required to override this switch. No attempt should be made to defeat it unless service is being performed by a qualified technician.
- DO NOT re-lamp the vender or attempt any repair to the lighting system unless power to the ballast is disconnected.
- ALWAYS disconnect power to the vender before attempting to service the evaporator fan or the condensor fan. Placing one's hands into the fan blade's path will result in cuts and bruises. Both fans are inaccessible without the use of tools.



Figure 2.8

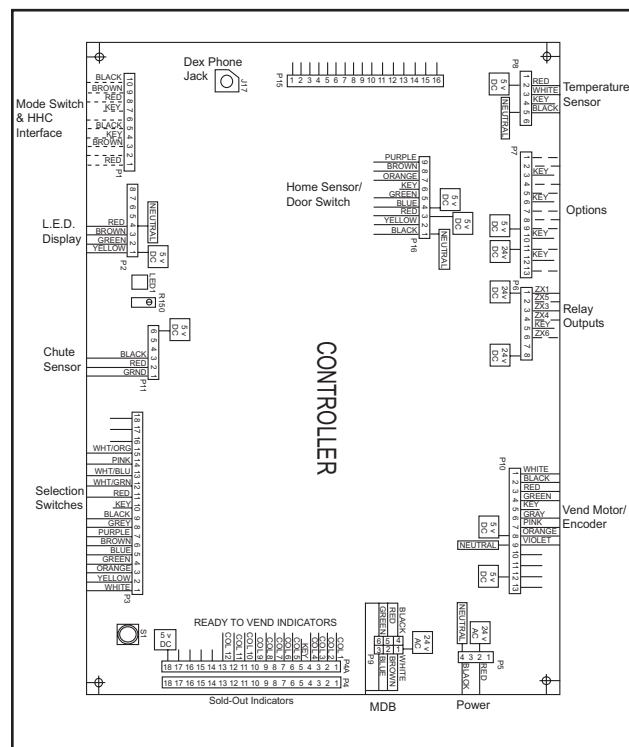

Figure 2.7

## Four-Button Programming

All programming of the vender options is done in the Service Mode. To enter the Service Mode, open the vender door and press and release the Service Mode Button which is located on the controller board (see Figure 2.7).

The first four selection switches are used to navigate through the service routines as follows:

Button	Meaning	Usage
1	(EXIT)	Escape, Cancel
2	(UP)	Increase, Next
3	(DOWN)	Decrease, Previous
4	(ENTER)	OK, Accept, Save

The controller will automatically return to the Closed-Door Mode if:

- 1) No response from the selection switches is received within approximately five minutes;
- 2) The Service Mode Button is pressed a second time; or
- 3) The "rtn" function is activated.

If the door is closed, the controller will return to the Sales Mode. If credit exists, the credit amount will be displayed after returning to the Sales Mode.

# SECTION 2: SET-UP AND INSTALLATION

## KO Programming Flowchart

### EXTERNAL MENU

Error  
CASH  
SALE  
rtn

### INTERNAL (SERVICE) MENU

Error  
CPO  
tuFL  
rPO  
tEst — UEnd — SL — SO — DSP  
PASS — CO1 - CO12  
rtn

Sel. Switch Test (1-16)  
LED Segments, Correct Change Lamp & Sold Out Lamp Flash Test

rELY  
Cap  
Fan  
Lit  
Htr

### PASSWORD PROTECTED MENU

CASH  
SALE  
CARD  
toKn  
FrEE  
PrIC  
StS — OPt1 - OPt9 — CSIS — rSIS  
Con — C1 — C2 — C3 — C4 — C5 — C7 — C8 — C9 — C10 — C11 — C16  
CCOC — Con — CCU — ACC  
PrEU

LANg — ENG — Frn — GER — Ita — Port — ESP — SLO — Fin — NOR — CUST  
time — Enb — YEAR — nth — date — Hour — dst  
Lit — Enb — day — Stop — dLAY — NA — OFF — AUS — EU  
rFrG — Enb — Strt — Stop — deG — SEtP — Stor — DSP — DEF — dLAY  
...  
Hour

If Configuration 2 is enabled, the following menus will appear:

blC1 — Enb — Strt — Stop — SEL — Lit  
day  
Hour

blC2 — Enb — Strt — Stop — SEL — Lit  
day  
Hour

DISC — Enb — Strt — Stop — SEL — LESS  
day  
Hour

OUER — FrE — Und — blC — dSC — Lit — FrG  
Hour

SDEP — 1 - 16 — ALL  
Set by selection

rUnd — Strt — Stop — SEL — rAtE  
day  
Hour





# SECTION 2: SET-UP AND INSTALLATION

## EMS Software

By capturing and remembering when sales are made over time, the machine's lighting and refrigeration systems can be powered down at periods of inactivity. This is made possible by the addition of the EMS software.

### What does the Delay (“dLAY”) setting represent in the Lighting Control and Refrigeration Control Modes?

The delay can be set anywhere from 0 minutes all the way up to 995 minutes. As an example, we will use a setting of 30 minutes for the Lighting Control delay and 90 minutes for the Refrigeration Control delay. This means, at these settings, if Lighting Control and Refrigeration Control are both Enabled to 2, the lights on the vender will come on 30 minutes prior to learned customer activity and turn off 30 after customer activity, based on what the EMS software has learned over a period of time. With the Refrigeration Control, the “dLAY” (Delay) value is only used when exiting conservation mode; thus, that the refrigeration system will turn on 90 minutes prior to learned customer activity.

*Note that in all venders with EMS Software, it is imperative that the time / date be set correctly in the Internal (Service) Menu. Incorrect time / date in the control board will cause a skewing of the pattern determined by the EMS Software, resulting in improper performance of the machine to the anticipated pattern.*

### Resetting the EMS time blocks

To reset the time blocks, simply change Lighting Control and Refrigeration Control so that both are both Enabled to 1. After changing them to 1, exit out of the Service Menu. Then, enter back into the menu and Enable Lighting Control and Refrigeration Control to 2.

## Internal (Service) Menu



### ERROR CODE DISPLAY MODE

If <enter> is pressed at the “Error” prompt, the controller will enter the error display mode. If no errors have occurred since the last error reset, the display will show “nonE.” If an error has been detected since the last error reset, the display will show the first summary error code that has occurred, such as “UEnd,” which would indicate a vend error. Pressing <up> or <down> will allow you to cycle through all of the summary error codes that are present. Pressing <enter> at the displayed summary error code will allow you to view the detailed error codes beneath the summary error heading (see below). Pressing <up> or <down> at this point will allow you to cycle through all of the detailed error codes that are present beneath the summary error code. If the <exit> button is pressed anytime during this operation, the controller will return to the “Error” prompt. Press the <up> button to proceed to the next prompt, “CPO.”

If <enter> is pressed and held for two seconds during the display of any detailed error code, that error will be cleared. If other errors exist that fall under the currently accessed detail type, the next error would be displayed. If no other errors of the current type exist, the next error summary code will be displayed, or “nonE” will be displayed if no other errors exist.

The error summary codes and their corresponding detailed error codes are as follows:

- **Ctrl (Control System Error)**  
By pressing <enter> at the “Ctrl” prompt, the controller will display:
  1. “dS,” indicating the door switch has been open for more than an hour;
  2. “rAn,” indicating the machine setup information has been corrupted;
  3. “ACLo,” indicating that the average rectified voltage was under 20 VDC for more than 30 seconds;

## SECTION 2: SET-UP AND INSTALLATION

4. “SF” indicating one of the credit peripherals has introduced an incompatible scaling factor;
5. “IS,” indicating the machine’s coin inlet sensor has been blocked for more than a minute (note: this is an optional component not installed on all venders); or
6. “Ib,” indicating two coins were sensed at the inlet sensor but didn’t make it to the changer within 10 seconds.

After taking corrective action to manually fix the “Ctrl” errors, the errors may be cleared electronically via a hand held device or through the service mode by pressing <enter> for two seconds.

- **SEL (Selection Switch Error)**

By pressing <enter> at the “SEL” prompt, the controller will display “SSXX,” where “XX” indicates the first selection switch that has been determined to be closed for more than 15 seconds. If there is a selection switch error, navigation of the service menu may not be possible. This error can only be cleared by manually correcting the problem.

- **CHAR (Coin Changer Error)**

By pressing <enter> at the “CHAR” prompt, the controller will display either:

1. “CC,” indicating no changer communications for more than 2 seconds;
2. “tS,” indicating a tube sensor error;
3. “IC,” indicating no coins sensed by acceptor for over 96 hours;
4. “tJXX,” indicating a tube jam error for coin type XX;
5. “CrCH,” indicating a changer ROM checksum error;
6. “EE” indicating more than 255 escrow attempts since the last coin was accepted;
7. “nJ,” indicating a coin jam; or
8. “LA,” indicating a low acceptance rate (more than 20% of the last 255 coins were slugs).

The “CC” error will be cleared when proper communications are re-established. After taking corrective action to manually fix the other “CHAR” problems, the errors may be cleared electronically via a hand held device or through the service mode by pressing <enter> for two seconds.

- **bUAL (Bill Validator Error)**

By pressing <enter> at the “bUAL” prompt, the controller will display either:

1. “bC,” indicating no bill validator communications for more than 5 seconds;
2. “bFuL,” indicating a full bill stacker;
3. “bILL,” indicating a defective motor;
4. “bJ,” indicating a bill jam error;
5. “brCH,” indicating a bill acceptor ROM check sum error;
6. “bOPn,” indicating an open cash box; or
7. “bS,” indicating a bill sensor error.

The “bC” error will be cleared when proper communications are re-established. After taking corrective action to manually fix the other “bUAL” problems, the errors may be cleared electronically via a hand held device or through the service mode by pressing <enter> for two seconds.

- **Crdr (Card Reader Error)**

By pressing <enter> at the “Crdr” prompt, the controller will display either:

1. “CrC,” indicating no card reader communications for more than 5 seconds; or
2. “CrXY,” indicating that a particular type of card reader malfunction occurred where “XY” indicates the error type.

The “CrC” error will be cleared when proper communications are re-established. The “CrXY” errors may be reset via the hand held device or through the service mode by pressing <enter> for two seconds.

- **UEnd (Vend Mechanism Error)**

By pressing <enter> at the “UEnd” prompt, the controller will display either:

1. “CJXX,” indicating a jam in column XX; or
2. “CS,” indicating that the chute sensor is active for more than 5 minutes.

After taking corrective action to manually fix the “UEnd” errors, the errors may be cleared electronically via a hand held device or through the service mode by pressing <enter> for two seconds.

## SECTION 2: SET-UP AND INSTALLATION

- **St5 (Space to Sales Error)**  
By pressing <enter> at the “StS” prompt, the controller will display “UAXX,” indicating that column XX is unassigned. These errors are cleared when new space to sales programming resolves the errors. (Note: When an unassigned button is selected in the sales mode, the display will show “Sold Out.”)
- **rFrG (Refrigeration Error)**  
By pressing <enter> at the “rFrG” prompt, the controller will display either:
  1. “SEnS,” indicating an unplugged temperature sensor error;
  2. “COLd,” indicating temperatures 1.5° C or more below the compressor cut-out setting;
  3. “HOt,” indicating temperatures 1.5° C or more above the compressor cut-in setting;
  4. “CnPr,” indicating that the compressor is not cooling at 0.5° C per hour or better while on; or
  5. “Htr,” indicating that the heating system is not heating at 0.5° C per hour or better while on.

The “SEnS” error will be cleared if the sensor is detected. The “COLd” error will be cleared when the temperature rises above the cut-out limit. The “HOt” error will be cleared when the temperature falls below the cut-in limit. The “CnPr” error will be cleared when the system cools at 0.5° C per hour or better. The “Htr” error will be cleared when the system heats at 0.5° C per hour or better.

A digital display showing the characters "CPO" in a white, segmented font on a black background.

### COIN PAY OUT MODE

If <enter> is pressed at the “CPO” prompt the controller will enter the coin payout mode by displaying the lowest coin value that can be paid out. Pressing <up> will increase the display to show the next highest coin value, pressing <down> will decrease the display to show the next lowest coin value or wrap around. Pressing <enter> when a particular coin value is displayed will pay out the displayed coin type at half-second intervals until the button is released. All coins dispensed in this mode are counted in the MIS tube counts and the manual dispense mode counters. Pressing <exit> while a coin value is displayed will return the controller to the “CPO” prompt. Use <up> to proceed to the next prompt, “tUFL.”

A digital display showing the characters "tUFL" in a white, segmented font on a black background.

### TUBE FILL MODE

If <enter> is pressed at the “tUFL” prompt the controller will enter the coin tube fill mode. In this mode, you are allowed to deposit any coin that is routed to a tube. This provides total accountability. The tube inventory level for the deposited coin will be displayed after the coin is accepted. If a tube full status is detected, that coin will no longer be accepted. During this entire operation, MIS tube counts and manual fill mode counters will be updated accordingly. If <exit> is pressed at any time during this operation, the controller will return to the “tUFL” prompt. Use <up> to proceed to the next prompt, “rPO.”

A digital display showing the characters "rPO" in a white, segmented font on a black background.

### RECYCLER PAY OUT MODE

If <enter> is pressed at the “rPO” prompt, the controller will enter the bill payout mode by displaying the lowest bill value that can be paid out. Pressing <up> will increase the display to show the next higher bill value, if any; pressing <down> will decrease the display to show the next lower bill value or wrap around. Pressing <enter> when a particular bill value is displayed will pay out the displayed bill type. All bills dispensed in this mode are counted in the MIS manual dispense mode counters. Pressing <exit> while a bill value is displayed will return the controller to the “rPO” prompt. Use <up> to proceed to the next prompt, “tEst.”

## SECTION 2: SET-UP AND INSTALLATION

TEST

### TEST MODES

If <enter> is pressed at the “tEST” prompt, the controller will enter the test mode by displaying “UEnd”. Using <up> or <down> will allow you to cycle through the available tests. If <exit> is pressed at any time, the controller will return to the “tEST” prompt. Use <up> to proceed to the next prompt, “PASS.”

- **UEnd (Column Test Vend)**

Pressing <enter> at the “UEnd” prompt will cause the controller to enter the column vend test routine. This routine will allow you to test each column motor. Upon entry into this routine, the display will show “CO 1,” indicating that a test vend from column 1 may be initiated. <Up> or <down> can be pressed to cycle through the available columns. Activation of <enter> at a displayed column will initiate a test vend on that column. Vends made while in this routine will not be added to the “SALE” mode totals. If <exit> is pressed at any time when “CONN” is displayed, the controller will return to the “Test Vend” prompt.

- **SL (Select Switch Test)**

If <enter> is pressed at the “SL” prompt, the controller will enter the selection switch test mode. The display will show “SL4,” which indicates that the fourth selection switch was pressed last. When any selection switch is pressed, it will be represented by the numbers shown after “SL.” The last selection switch pressed will remain on the display until the service mode timer expires or the <exit> button is pressed for two seconds. This will return the controller to the “SL” prompt. Press <up> to proceed to the next prompt, “SO.”

- **SO (Sold Out Test)**

Pressing <enter> at the “SO” prompt will cause the controller to enter the sold out test routine. The display will show “C1X,” which represents column 1. If the column number is followed by “0,” the column is not sold out; if the column number is followed by “1,” the column is sold out. Pressing <up> or <down> will allow you to cycle through all the available columns. Pressing <enter> has no action. Pressing <exit> will return the controller to the “SO” prompt. Press <up> to proceed to the next prompt, “dSP.”

- **dSP (Display Test)**

Pressing <enter> at the “dSP” prompt will cause the controller to enter the display test routine. This routine allows you to test the display. Upon entry into this routine, all segments of the display, the correct-change only light, and the sold-out light will run a diagnostic test until a timer expires or <exit> is pressed. This will return the controller to the “dSP” prompt. Press the <up> button to proceed to the next prompt in the test mode, “rELy.”

- **rELy (Relay Test)**

Pressing <enter> at the “rELy” prompt will cause the controller to enter the relay test routine, which allows you to test the available relays. Upon entry, the display will show the state of the first relay, “CnPX”, where X = “1” (on) or “0” (off). Pressing <up> or <down> will cycle through the available relay tests (listed below). Pressing <enter> at the displayed relay will toggle its state. Note: To prevent equipment malfunctions, relay states should not be toggled more than once every 10 seconds. If <exit> is pressed at any time, the controller will return to the “rELy” prompt. Press the <up> button to proceed to the last prompt in the test mode, “SEnS.”

CnP - controls the compressor relay

FAn - controls the evaporator fan relay

Lt - controls the sign front light relay

Ht - controls the heater relay

- **SEnS (Motion Sensor Test)**

Pressing <enter> at the “SEnS” prompt will cause the controller to enter the motion sensor test routine, which allows you to test the functional ability of the motion sensor. Upon entry, the display will show “0” to indicate no motion is detected. To test the sensor, walk from side to side, each direction, in front of the machine. The display should briefly change to “1” when motion is detected. *Note: The sensor cannot be tested by standing stationary in front of the vender or by waving a hand or other object.* If <exit> is pressed at any time, the controller will return to the “SEnS” prompt.

## SECTION 2: SET-UP AND INSTALLATION

**PASS**

### PASSWORD PROTECTION

“PASS” will be displayed only if the password has not been entered. The password is entered via the first four selection switches while the controller is displaying “PASS.” The password must be entered within ten seconds in the following order: 4-2-3-1. The display will be blank after the first selection switch is pressed. After completing the sequence, press <enter>. If the password is not recognized, the display will return to “PASS.” If the password is correctly entered, the display will show “CASH.”

**CASH**

### CASH COUNTER DISPLAY MODE

If <enter> is pressed at the “CASH” prompt, the controller will enter the non-resettable cash display mode by displaying “CASH” / “XXXX” / “XX.XX,” where the X’s will represent total cash over the life of the vender’s control board. A decimal point will be displayed in the appropriate position with the lower four digits. If the cash amount is less than five digits long, the upper four-digit set is not displayed. Using <up> or <down> will cycle through each selection as “CANN” / “XXXX” / “XX.XX,” where the N’s represent the appropriate selection number and the X’s represent the resettable cash count for that selection. If <exit> is pressed at any time during this operation, the controller will return to the code level. Press the <up> button to proceed to the next prompt, “SALE.”

**CLEARING INDIVIDUAL COUNTERS:** If the Configurations Mode is set to allow the individual counters to be reset, the individual counters will be reset upon reading at least one of them and closing the vender’s main door.

**SALE**

### SALE COUNTER DISPLAY MODE

If <enter> is pressed at the “SALE” prompt, the controller will enter the non-resettable vend count display mode by displaying “SALE” / “XXXX” / “XXXX,” where the X’s will represent total number of all paid vends over the life of the vender’s control board. If the sales amount is less than five digits long, the upper four-digit set is not displayed. Using <up> or <down> will cycle through each selection as “SLNN” / “XXXX” / “XXXX,” where the N’s represent the appropriate selection number and the X’s represent the resettable vend count for that selection. If <exit> is pressed at any time during this operation, the controller will return to the code level. Press the <up> button to proceed to the next prompt, “CArd.”

**CLEARING INDIVIDUAL COUNTERS:** If the Configurations Mode is set to allow the individual counters to be reset, the individual counters will be reset upon reading at least one of them and closing the vender’s main door.

**CArd**

### CARD COUNTER DISPLAY MODE

The Card Counter Display Mode is used to track cash and sales counts of all vends made by using a debit or credit card. If <enter> is pressed at the “CArd” prompt, the controller will enter the first of two sub-menus, “CASH.” If <exit> is pressed at any time during this operation, the controller will return to the code level. Press the <up> button to proceed to the next prompt, “toKn.”

If <enter> is pressed at the “CASH” prompt, the controller will enter the non-resettable cash display mode by showing “totL” / “XXXX” / “XX.XX,” where the X’s will represent the total value of all card sales over the life of the vender’s control board. A decimal point will be displayed in the appropriate position with the lower four digits. If the cash amount is less than five digits long, the upper four-digit set is not displayed. Using <up> or <down> will cycle through each selection as “CANN” / “XXXX” / “XX.XX,” where the N’s represent the appropriate selection number. The individual selection counts are resettable. If <exit> is pressed, the controller will return to the “CASH” prompt. Press <up> to proceed to the next prompt, “SALE.”

If <enter> is pressed at the “SALE” prompt, the controller will enter the non-resettable card sale vend count display mode by showing “totL” / “XXXX” / “XXXX,” where the X’s will represent the total number of all card sales over the life of the vender’s control board. Using <up> or <down> will cycle through each selection as “SLNN” / “XXXX” / “XXXX,” where the N’s represent the appropriate selection number. The individual selection counts are resettable. If <exit> is pressed, the controller will return to the “SALE” prompt. Press <exit> again to return to the “CArd” prompt.

## SECTION 2: SET-UP AND INSTALLATION



### TOKEN COUNTER DISPLAY MODE

The Token Counter Display Mode is used to track cash and sales counts of all vends made by using a vend token. If <enter> is pressed at the “toKn” prompt, the controller will enter the first of two sub-menus, “CASH.” If <exit> is pressed at any time during this operation, the controller will return to the code level. Press the <up> button to proceed to the next prompt, “FrEE.”

If <enter> is pressed at the “CASH” prompt, the controller will enter the non-resettable cash display mode by showing “totL” / “XXXX” / “XX.XX,” where the X’s will represent the total value of all vend token sales over the life of the vender’s control board. A decimal point will be displayed in the appropriate position with the lower four digits. If the cash amount is less than five digits long, the upper four-digit set is not displayed. Using <up> or <down> will cycle through each selection as “CANN” / “XXXX” / “XX.XX,” where the N’s represent the appropriate selection number. The individual selection counts are resettable. If <exit> is pressed, the controller will return to the “CASH” prompt. Press <up> to proceed to the next prompt, “SALE.”

If <enter> is pressed at the “SALE” prompt, the controller will enter the non-resettable card sale vend count display mode by showing “totL” / “XXXX” / “XXXX,” where the X’s will represent the total number of all vend token sales over the life of the vender’s control board. Using <up> or <down> will cycle through each selection as “SLNN” / “XXXX” / “XXXX,” where the N’s represent the appropriate selection number. The individual selection counts are resettable. If <exit> is pressed, the controller will return to the “SALE” prompt. Press <exit> again to return to the “toKn” prompt.



### FREE VEND ACCOUNTING MODE

The Free Vend Accounting Mode is used to track cash counts, sales counts, and cost of all free vends. If <enter> is pressed at the “FrEE” prompt, the controller will enter the first of three sub-menus, “CASH.” If <exit> is pressed at any time during this operation, the controller will return to the code level. Press the <up> button to proceed to the next prompt, “Pric.”

If <enter> is pressed at the “CASH” prompt, the controller will enter the non-resettable cash value display mode by showing “totL” / “XXXX” / “XX.XX,” where the X’s will represent the total equivalent value of all free vends over the life of the vender’s control board. A decimal point will be displayed in the appropriate position with the lower four digits. If the cash amount is less than five digits long, the upper four-digit set is not displayed. Using <up> or <down> will cycle through each selection as “CANN” / “XXXX” / “XX.XX,” where the N’s represent the appropriate selection number. The individual selection counts are resettable. If <exit> is pressed, the controller will return to the “CASH” prompt. Press <up> to proceed to the next prompt, “SALE.”

If <enter> is pressed at the “SALE” prompt, the controller will enter the non-resettable free vend count display mode by showing “totL” / “XXXX” / “XXXX,” where the X’s will represent the total number of all free vends over the life of the vender’s control board. Using <up> or <down> will cycle through each selection as “SLNN” / “XXXX” / “XXXX,” where the N’s represent the appropriate selection number. The individual selection counts are resettable. If <exit> is pressed, the controller will return to the “SALE” prompt. Press <up> to proceed to the next prompt, “CoSt.”

If <enter> is pressed at the “CoSt” prompt, the controller will enter the free vend equivalent cost display mode by displaying “CANN” / “XX.XX,” where the N’s represent the appropriate selection number. The X’s represent the last saved price for that selection that is not 00.00. A decimal will be displayed in the appropriate position. Using <up> or <down> will cycle through each selection. If <exit> is pressed, the controller will return to the “CoSt” prompt. Press <exit> again to return to the “FrEE” prompt.

## SECTION 2: SET-UP AND INSTALLATION



### PRICE SETTING MODE

If <enter> is pressed at the “Pric” prompt, the controller will enter the selection price setting mode. If multiple prices are enabled (at “C1” in configurations mode), the controller will display “ALL,” for the universal selection price. If <up> is pressed, the controller will display “Pr 1,” for the price of selection 1. The current set price for selection 1 will alternate with the “Pr 1” display. Using <up> or <down> will cycle through each individual selection price. If <enter> is pressed at “PrXX” (where “XX” represents the selection number), the display will show the current price for the displayed selection. Use <up> or <down> to increase or decrease the price. When the desired price is on the display, use <enter> to save that price and return to the “PrXX” display. If the “ALL” price is set and saved, all individual selection prices will be set to that value. Pressing <exit> while a selection is displayed will return the controller to the “Pric” prompt without saving. Use <up> to proceed to the next prompt, “StS.”

If single price mode is enabled, only the single price can be adjusted. In single price mode, “SPri” will be displayed after pressing <enter> at the “Pric” prompt. If <enter> is pressed at “SPri,” the display will show the current price. Pressing <up> or <down> will increase or decrease this price. When the desired price is on the display, press <enter> to save that price and return to the “SPri” prompt, then press <exit> to return to the “Pric” prompt. Press <up> to proceed to the next prompt, “StS.”



### SPACE-TO-SALES PROGRAMMING MODE

The space-to-sales mode is used to determine which column(s) will vend for each selection. If <enter> is pressed at the “StS” prompt, the controller will enter the space-to-sales mode by displaying “CStS,” if a custom space-to-sales configuration is currently used; “rStS,” if a vender-recommended space-to-sales configuration is currently used; or “OPTX,” where “X” is the current option selected. Using <up> or <down> will cycle through the available space-to-sales options, as well as the “CStS” and “rStS” options. After setting space-to-sales and returning to the “StS” prompt, use <up> to proceed to the next prompt, “Con.”

#### CSStS (Custom Space-to-sales)

If <enter> is pressed at the “CStS” prompt, the controller will enter the custom space-to-sales option. Upon entry into this routine, the display will show “CLr,” meaning “clear.” Pressing <exit> will return the controller to the “CStS” prompt with no changes being made. Pressing <up> or <down> at the “CLr” prompt will display “SLXX,” followed by the current cell assignments for

selection XX. If “SLXX” is flashing and not followed by a column number, there are no columns assigned to selection XX. Using <up> or <down> will cycle through all the available selections and their associated column assignments.

Pressing <enter> at the “SLXX” prompt will allow the assignment of columns to selection XX. The display will show “CnnY,” where “nn” is the column number and “Y” is the currently assigned state of that column (“1” = assigned, “0” = unassigned). Using <up> or <down> will allow you to cycle through all the columns. Pressing <enter> when “CnnY” is displayed will cause “Y” to flash. Press <up> or <down> to toggle “Y” between “0” and “1.” When the desired setting is displayed, press <enter> to save the displayed status and return to the “CnnY” prompt, where “Y” no longer flashes. If <exit> is pressed, the display will return to the “SLXX” prompt. Once all space-to-sales assignments have been completed, press <exit>; the display will show “SAUE.” Press <enter> to save these settings and return the display to the “StS” prompt.

**NOTE:** Selection pricing must be aligned with the space-to-sales assignments.

#### rStS (Recommended Space-to-sales)

If <enter> is pressed at the “rStS” prompt, a recommended space-to-sales configuration is calculated, based on first choice attempts since space-to-sales was last changed. The display will flash “SL1” and alternate this message with either “nonE,” indicating that no columns should be assigned to selection 1, or a sequence of numbers that represent columns that should be assigned to selection 1. Press <up> or <down> to cycle through the remaining selections. If <enter> or <exit> is pressed, the display will show “SAUE,” where pressing <enter> will save the recommended space-to-sales; pressing <exit> will return the controller to the “StS” prompt without saving the recommended space-to-sales.

#### OPT (Options)

When one of the options (OPTX) is on the display and <enter> is pressed, the display will begin displaying the space-to-sales assignments for that configuration. The display will show “SLXX” (where the X’s represent the selection number), followed by either a blank display, indicating that no columns are assigned to that selection; or a sequence of numbers that represent the columns that are currently assigned to that selection. Using <up> or <down> will cycle through the space-to-sales assignments for the other selections. If <exit> is pressed at this time, the display will return to the “StS” prompt, and the option that was being viewed will be saved as the current space-to-sales configuration. From “StS,” press <up> to proceed to the next prompt, “Con.”

## SECTION 2: SET-UP AND INSTALLATION



### CONFIGURATIONS MODE

If <enter> is pressed at the “Con” prompt, the controller will enter the configurations mode by displaying “Cn X,” where “n” is the configuration number and “X” is the current status. Using <up> or <down> will cycle through all available configuration options. If <exit> is pressed at any time during this operation, the controller will return to the “Con” prompt. From the “Con” prompt, use <up> to proceed to the next prompt, “CCOC.”

If <enter> is pressed, the display will flash “X” (the current status). Pressing <up> or <down> will cause the flashing status to toggle between “0” (disabled) and “1” (enabled). When the desired status is displayed, pressing <enter> will save that status and return the controller to the “Cn X” display.

- **Ⓛ1 - Single price / multi-price**

This option is used to toggle between the single-price and multi-price modes. In the single-price mode, one price will be used for all selections. In the multi-price mode, each selection may be set to a different price.

If X = 0, single pricing is used.

If X = 1, multi-pricing is used.

- **Ⓛ2 - Optional menu enable**

This option is used to enable the optional menu, which contains several more mode options than available in the standard service menu. If this configuration is set to “0,” all optional menu items will be disabled (except “SdEP”).

If X = 0, the optional menu items will not appear.

If X = 1, the optional menu items will appear.

- **Ⓛ3 - POS message disable**

This option is used to turn off the display of the point-of-sales message (“ICE COLd,” etc.).

If X = 0, the point-of-sales greeting will appear as normal.

If X = 1, the point-of-sales greeting will not appear on the display.

- **Ⓛ4 - Open-door totals**

This option is used to turn on the display of the total machine sales and total machine cash values in the open-door mode.

If X = 0, only error codes or “nonE” are displayed when the door is opened.

If X = 1, sales and cash totals will be displayed, and “Error” or “nonE” will replace the error codes when the door is opened.

- **Ⓛ5 - Door switch reset**

This option is used to allow the door switch to reset all resettable MIS.

If X = 0, all resettable MIS registers are reset only when the “CF” command is received from the Hand Held Computer (HHC).

If X = 1, all resettable MIS registers are reset when the door switch is sensed as open and at least one of the resettable MIS registers has been read (i.e., cash and sales counts).

- **Ⓛ7 - Save credit**

This option is used to determine how long credit should remain on the display and available to the customer. If the feature is turned off, a five-minute timer is restarted each time credit is added to the machine, or any valid consumer action occurs. After the timer expires the credit is erased. If the feature is turned on, credit is left available to the customer regardless of when it was deposited.

If X = 0, the five-minute timer is used.

If X = 1, credit is left on the display for use indefinitely.



## SECTION 2: SET-UP AND INSTALLATION

- **⌘8 - Forced vend attempt**

This option prevents the machine from becoming a change maker. When this mode is enabled, escrow of coins is allowed until any of the following three events occurs: 1. Any bill is inserted into the bill acceptor; 2. Any “cash box” coin is inserted into the changer; or 3. The maximum vend price is reached. Once any of these conditions are met, any accumulated credit must be used toward a vend attempt, and coins will not be dispensed for credit in response to an escrow request. If a sold-out selection, or if a valid selection that becomes sold-out, is made, this option will be overridden and an escrow will be honoured.

If X = 0, forced vend attempt is disabled.

If X = 1, forced vend attempt is enabled.

Note that forced vend attempt has no effect on the card reader. Once a card is inserted, it can always be returned to the customer via the escrow lever on the changer or return button on the card reader.

- **⌘9 - Multi-vend**

This option will allow multiple purchases without re-entering coins. If enabled, instead of immediately returning the change after a vend, the credit will remain on the display to be used for another selection. An escrow request will be honoured at any time. This option will take precedence over the forced-vend option after the first vend has been completed.

If X = 0, multi-vend is disabled.

If X = 1, multi-vend is enabled.

- **⌘10 - Bill escrow inhibit**

This option will inhibit escrowing of bills. If disabled, and the current bill value inserted takes the accumulated credit over the maximum price, the bill will be held in the escrow position. If the rule is enabled, bills will always go to the cash box.

If X = 0, bill escrow is allowed.

If X = 1, bill escrow is inhibited.

- **⌘11 - ENERGY STAR® Tier Setting**

ENERGY STAR is a government-led program to promote energy-efficient products. All venders built for use in the USA and Canada since April 2004 are ENERGY STAR-compliant. Beginning with serial numbers 200724 and after, these venders are now ENERGY STAR Tier 2-compliant, which denotes even greater energy efficiency. Tier 2-compliant venders can be identified by the placement of the temperature sensor. In older venders,

the temperature sensor was mounted on the rear cabinet wall behind the evaporator fan. On Tier 2-compliant venders, the temperature sensor is mounted in front of the evaporator, directly below the chute assembly.

The new features of ENERGY STAR Tier 2-compliant venders are:

- **Normal Mode (Energy Saving):** When the main door is closed and the door switch is made, the controller will count the number of refrigeration cycles. When this number equals a stored counter, the refrigeration unit will convert from a pull-down mode, in which the evaporator fan runs continuously, to a normal mode, in which the evaporator fan runs only when the compressor is on.
- **Defrost Mode:** The defrost feature is a 30-minute period in which the compressor is shut off and the evaporator fan is allowed to run. The defrost feature is initiated by a timer. The factory default is three hours, but this setting may be adjusted in the Refrigeration Control Mode from 3 to 24 hours.

*IT IS IMPERATIVE THAT CONFIGURATION 11 BE SET CORRECTLY.* Possible problems due to incorrect setting of this configuration include:

- **TIER 1:** If a Tier 1-compliant or non-Energy Star vender’s controller is set for Tier 2 operation, the refrigeration unit could short-cycle, eventually shutting off the unit completely.
- **TIER 2:** If a Tier 2-compliant vender’s controller is set for Tier 1 operation, the refrigeration unit could freeze up and shut down. A “PULL” error will be shown in the vender’s error codes.

This configuration should be set as follows:

If X = 0, the controller is set for Tier 1 operation.

*(NOTE: All venders built for use outside the USA and Canada should be set to “0.”)*

If X = 1, the controller is set for Tier 2 operation.

- **⌘15 - Reader MDB Level**

This option allows cashless devices (such as card readers) to use MDB Level 2 communication protocol. When enabled, card revaluing is supported.

If X = 0, MDB Level 2 is disabled for cashless devices (no card revaluing).

If X = 1, MDB Level 2 is enabled for cashless devices (i.e., card revaluing is enabled).

## SECTION 2: SET-UP AND INSTALLATION



### CORRECT CHANGE ONLY CONTROL MODE

If <enter> is pressed at the “CCOC” prompt, the display will show “Con.” Using <up> or <down> will cycle through all available correct change options, as listed below. Pressing <exit> at any point in this procedure will return to the “CCOC” prompt without saving any changes. Use <up> to proceed to the next prompt, “PrEU.”

- **Con (Consumer Overpay X)**

This submode is used to determine whether a vend should be allowed when an overpayment situation may result. If set to “0,” the customer will not be cheated.

When set to “1,” if a customer makes a selection when the change levels are low and the “Use Correct Change Only” light is:

- OFF: The light will continue to flash for up to one minute. If after 2 seconds but before one minute expires the customer re-selects this same selection, the vend will continue and as much change as possible will be returned.
- ON: The light will continue to flash for up to one minute. However, the vend will continue and as much change as possible will be returned. The light will return to its appropriate state when the flashing period has ended.

In either case above, remaining change due back to the customer will remain on the display. The customer may add change to the remaining value on the display to make another vend.

*Note: If “Con” is set to 1, both “CCU” and “ACC” will apply; if set to 0, only “CCU” will apply.*

- **CCU (Correct Change Value)**

When <enter> is pressed at “CCU,” the display will show a value. The changer must be able to pay back this value and all values below that (in increments of the changer’s lowest tube value) in order for the correct-change message to remain off. In other words, if “CCU” is set to 0.25, the changer must be able to pay back 0.25, 0.20, 0.15, 0.10, and 0.05 in any combination, or else the correct-change light will be lit. If this value is set to 0.00, the “Use Correct Change Only” light will never illuminate.

- **ACC (Unconditional Acceptance Value)**

When <enter> is pressed at “ACC,” the display will show a value. The vender should not accept any amount of currency (bill or coin) larger than the value set in “ACC” unless the changer can pay out the equivalent of that amount.



### PASSWORD PREVIEW MODE

On the GIII vender, the total historical and individual cash and sales counts can be accessed externally, as well as the error mode, by entering the external password. Neither the cash and sales counts nor the errors can be cleared externally. The Password Preview Mode allows the external password to be changed.

If <enter> is pressed at the “PrEU” prompt, the controller will display the external password preview mode. The first digit of the number will be flashing. Pressing <up> or <down> will adjust the currently flashing digit up or down. Pressing <enter> will save the currently flashing digit and cause the next digit of the password to begin flashing. All digits may be modified in this manner. Pressing <exit> at any point in this procedure will return the controller to the “PrEU” prompt without saving any changes. Pressing <enter> while the last digit of the password is flashing will save the currently displayed password and return the controller to the “PrEU” prompt. Use <up> to proceed to the next prompt, “LANG.”

*Note: Password digits correspond to the selection switches. If a digit is set to “0” (zero), it will not be possible to enter the external password.*

## SECTION 2: SET-UP AND INSTALLATION



### LANGUAGE SELECTION MODE

The GIII vender has the ability to display vending messages (“ICE COLd,” “SOLd Out,” etc.) in any of several preset languages. The available languages are listed below.

If <enter> is pressed at the “LANG” prompt, the controller will display the current language setting. Pressing <up> or <down> will sequence through the available languages:

- CUSE Custom language selection
- ENG English
- FRN French
- GER German
- ITR Italian
- PORt Portuguese
- ESP Spanish
- SLO Slovenian
- FIN Finnish
- NOR Norwegian

Pressing <enter> at any point in the procedure will save the currently displayed language setting and return the controller to the “LANG” prompt. Use <up> to proceed to the next prompt, “tinE.”



### TIME PROGRAMMING MODE

If <enter> is pressed at the “tinE” prompt, the controller will enter the current time setting mode by displaying “Enb.” Using <up> or <down> will allow you to cycle through all available time programming options. If <exit> is pressed anytime during this operation, the controller will return to the “tinE” prompt. Use <up> to proceed to the next prompt, “Lit.”

- **Enb (Enable)**  
If <enter> is pressed at the “Enb” prompt, the current value of the enable setting is displayed as “EnbX,” where the X value will be “0” if the real-time clock circuit is disabled or “1” if the circuit is enabled. This setting controls the time and date support by keeping a continuously updated clock connection, when set to “1.” Pressing <up> or <down> will toggle between “0” and “1.” Pressing <enter> will save the displayed setting and return you to the “Enb” prompt. Press <up> to proceed to the next prompt, “YEAr.”

*NOTE: “Enb” should be set to “1” at all times to ensure proper vending operations.*

- **YEAr (Year)**  
If <enter> is pressed at the “YEAr” prompt, the current year setting is displayed and will be flashing. Pressing <up> or <down> at this point will increase or decrease the year setting. Pressing <enter> will save the displayed year setting and return you to the “YEAr” prompt. Use <up> to proceed to the next prompt, “nth.”
- **ntH (Month)**  
If <enter> is pressed at the “ntH” prompt, the current month setting is displayed and will be flashing. Pressing <up> or <down> at this point will increase or decrease the month setting. Pressing <enter> will save the displayed month setting and return you to the “ntH” prompt. Use <up> to proceed to the next prompt, “dAtE.”
- **dAtE (Date)**  
If <enter> is pressed at the “dAtE” prompt, the current two digit date-of-the-month setting (01-31) is displayed. Pressing <up> or <down> at this point will increase or decrease this number. If <enter> is pressed, the currently displayed date is saved and the controller will return to the “dAtE” prompt. Use <up> to proceed to the next prompt, “Hour.”

## SECTION 2: SET-UP AND INSTALLATION

- **Hour (Hour)**

If <enter> is pressed at the “Hour” prompt, the current time is displayed in a 24-hour format. The left two digits of the display show the current hour setting; the right two digits show the current minutes. The hour setting will be flashing. Pressing <up> or <down> at this point will increase or decrease the hour setting. If <enter> is pressed, the minute setting will flash. Pressing <up> or <down> at this point will increase or decrease the minutes setting. Pressing <enter> again will save the displayed hour and minutes setting and return you to the “Hour” prompt. Pressing <exit> while in editing mode will return you to the “Hour” prompt without saving changes. Use <up> to proceed to the next prompt, “dSt.”
- **dSt (Daylight Savings Time)**

If <enter> is pressed at the “dSt” prompt, the controller will enter the daylight savings time setting routine. Daylight savings time start and stop is set by programming specific month, day of week, occurrence of day, and time. For example March (03), Sunday (Sun), first Sunday (1), 2 a.m. (0200). Upon entry into this routine, the display will show the first summary level code, “EnbX.” Using the <up> or <down> buttons will rotate through the available options listed below. Pressing <enter> will enter the detail level routines. Pressing <exit> at the “dSt” prompt has no action.

  - ▶ **Enb (Enable):** If <enter> is pressed at the “Enb” prompt, the current value of the enable setting is displayed as “EnbX,” where the X value will be “0” if the daylight savings time change is disabled or “1” if the daylight savings time change is enabled. While enabled, the time will automatically adjust for daylight savings time based on the settings below. Pressing <up> or <down> will toggle between “0” and “1.” Pressing <enter> will save the displayed setting and return you to the “Enb” prompt. Press <up> to proceed to the next prompt, “Strt.”
  - ▶ **StT (Start):** If <enter> is pressed at the “Strt” prompt, the controller will enter the daylight saving start (forward) time setting routine. Upon entry into this routine, the display will show the first summary level code, “nTH.” Pressing <up> or <down> will cycle through the available summary codes listed below. Pressing <exit> at this point will return you to the “Strt” prompt without saving any changes. Use <up> to proceed to the next prompt, “StoP.”
    - **nTH (Month):** If <enter> is pressed at the “nTH” prompt, the controller will enter the month setting routine. Upon entry into this routine, the display will show the current two digit month setting, indicating the month of the year (01-12). Using <up> or <down> will increase or decrease the number. Pressing <enter> will save the month and return to the “nTH” prompt. Press <up> to proceed to the next prompt, “dAy.”
    - **dAy (Day):** If <enter> is pressed at the “dAy” prompt, the controller will enter the day of week setting routine. Upon entry into this routine, the display will show the current day setting. Using <up> or <down> will rotate through “non,” “tUE,” “UEd,” “tHu,” “FrI,” “SAT,” or “Sun.” Pressing <up> will save the day and return to the “dAy” prompt. Press <up> to proceed to the next prompt, “oCC.”
    - **oCC (Occurrence):** If <enter> is pressed at the “oCC” prompt, the controller will enter the occurrence of day of week setting routine. Upon entry into this routine, the display will show the current setting. Use <up> or <down> to rotate through “1” (first), “2,” “3,” “4,” “5.” Press <enter> to save the occurrence and return to the “oCC” prompt. Press <up> to proceed to the next prompt, “Hour.” *Note: In months that have only four weeks, the controller will interpret occurrence settings of “5” as the last week in the month.*
    - **Hour (Hour):** If <enter> is pressed at the “Hour” prompt, the controller will enter the hour setting routine. Upon entry into this routine, the display will show the current four-digit hour and minute setting, in 24-hour format (0000, midnight, to 2359). The hour setting will be flashing, indicating that it can be edited. Use <up> or <down> to increase or decrease the number. Pressing <enter> will cause the minute setting to begin flashing, indicating that it can now be edited. Use <up> or <down> to increase or decrease the number. Pressing <enter> will save the hour and minute setting, and return the controller to the “Hour” prompt. Press <exit> to return to the “Strt” prompt.
    - ▶ **StoP (Stop):** If <enter> is pressed at the “StoP” prompt, the controller will enter the daylight saving stop (backward) time setting routine. Upon entry into this routine the display will show the first summary level code, “nTH.” Use <up> or <down> to cycle through the available summary level codes as listed below. Pressing <enter> will enter the detail level routines.

## SECTION 2: SET-UP AND INSTALLATION

Pressing <exit> while a summary level prompt is displayed will return the controller to the “StoP” prompt. Pressing <exit> at the “StoP” prompt will return the controller to the “dSt” prompt.

- **ᠨᠡᠬᠡ (Month):** If <enter> is pressed at the “ntH” prompt, the controller will enter the month setting routine. Upon entry into this routine, the display will show the current two digit month setting, indicating the month of the year (01-12). Using <up> or <down> will increase or decrease the number. Pressing <enter> will save the month and return to the “ntH” prompt. Press <up> to proceed to the next prompt, “dAy.”
- **ᠳᠠᠶᠢ (Day):** If <enter> is pressed at the “dAy” prompt, the controller will enter the day of week setting routine. Upon entry into this routine, the display will show the current day setting. Using <up> or <down> will rotate through “non,” “tUE,” “UEd,” “tHu,” “FrI,” “SAt,” or “Sun.” Pressing <up> will save the day and return to the “dAy” prompt. Press <up> to proceed to the next prompt, “oCC.”
- **ᠠᠴᠴᠢ (Occurrence):** If <enter> is pressed at the “oCC” prompt, the controller will enter the occurrence of day of week setting routine. Upon entry into this routine, the display will show the current setting. Use <up> or <down> to rotate through “1” (first), “2,” “3,” “4,” “5.” Press <enter> to save the occurrence and return to the “oCC” prompt. Press <up> to proceed to the next prompt, “Hour.” *Note: In months that have only four weeks, the controller will interpret occurrence settings of “5” as the last week in the month.*
- **Hour (Hour):** If <enter> is pressed at the “Hour” prompt, the controller will enter the hour setting routine. Upon entry into this routine, the display will show the current four-digit hour and minute setting, in 24-hour format (0000, midnight, to 2359). The hour setting will be flashing, indicating that it can be edited. Use <up> or <down> to increase or decrease the number. Pressing <enter> will cause the minute setting to begin flashing, indicating that it can now be edited. Use <up> or <down> to increase or decrease the number. Pressing <enter> will save the hour and minute setting, and return the controller to the “Hour” prompt. Press <exit> to return to the “Strt” prompt.



### LIGHTING CONTROL MODE

If <enter> is pressed at the “LIt” prompt, the controller will enter the lighting control mode. Using <up> or <down>, you can cycle through the various lighting control settings (“Enb,” “Strt,” “StoP,” and “dLAy”). If <exit> is pressed, the controller will return to the “LIt” prompt. From this prompt, press <up> to proceed to the next prompt, “rFrG.”

- **ᠡᠨᠪᠢ (Enable)**  
If <enter> is pressed at the “Enb” prompt, the current value of the enable setting is displayed as “EnbX,” where the X value will be “0” if the lighting control is disabled, “1” if the day- and time-based lighting conservation control is enabled, or “2” if the activity-based lighting conservation control is enabled. While enabled, the lighting panels of the vender will be turned off during the programmed time blocks if X = 1 or be controlled by the learned activity if X = 2. Using <up> or <down> will toggle between 0, 1, and 2. Pressing <enter> will save the displayed setting and return you to the non-editable “Enb” prompt. From the “Enb” prompt, use <up> to proceed to the next prompt, “Strt.”

If X=0, the lighting control is (off) disabled.

If X=1, the lighting control is (on) enabled.

If X=2, lighting control is controlled by learned activity.

- **ᠰᠢᠷᠲᠢ (Start Time)**  
If <enter> is pressed at the “Strt” prompt, the controller will enter the start lighting control time setting routing. Upon entry into this routine, the display will show the first of the two start time setting modes, “dAy.” Pressing <up> or <down> will cycle between “dAy” and “Hour.” Pressing <exit> at this point will return you to the “Strt” prompt without saving any changes. Use <up> to proceed to the next prompt, “StoP.”

If <enter> is pressed at the “dAy” prompt, the controller will enter the day of the week setting routine. The display will show “YY X”, where “YY” is the day of the week (“SUn,” “non,” “tUE,” “UEd,” “tHu,” “FrI,” “SAt,” or “ALL”) and “X” is either “1” or “0”. Pressing <up> or <down> will cycle through the days of the week. If <enter> is pressed at the “YY X” prompt, “X” will flash, indicating that it can be changed. Pressing <up> or <down> will toggle “X” between “1” (enabled) and “0” (disabled). Pressing <enter> again will save the displayed setting and return you to the non-flashing “YY X” prompt. Pressing <exit> will return the controller to the “dAy” prompt.

## SECTION 2: SET-UP AND INSTALLATION

---

If <enter> is pressed at the “Hour” prompt, the controller will enter the start time setting routine. The display will show the current four-digit hour and minute setting in 24-hour format. The hour setting will be flashing to indicate that it can be modified. Pressing <up> or <down> will increase or decrease the hour. Pressing <enter> will stop the hour from flashing and cause the minutes to flash, indicating they can be modified. Pressing <up> or <down> will increase or decrease the minutes value. Pressing <enter> again will save the displayed setting and return you to the “Hour” prompt. Pressing <exit> while in editing mode will return the controller to the “Hour” prompt without saving changes.

- **StoP (Stop Time)**

If <enter> is pressed at the “StoP” prompt, the controller will enter the stop lighting control time setting routine. Upon entry into this routine, the display will show the first of the two stop time setting modes, “dAy” and “Hour.” Pressing <up> or <down> will cycle between the two. Pressing <exit> at this point will return to the “StoP” prompt without saving any changes. From this prompt, press <exit> to return to the “Lit” prompt.

If <enter> is pressed at the “dAy” prompt, the controller will enter the day of the week setting routine. The display will show “YY X”, where “YY” is the day of the week (“SUn,” “non,” “tUE,” “UEd,” “thU,” “Fri,” “SAt,” or “ALL”) and “X” is either “1” or “0”. Pressing <up> or <down> will cycle through the days of the week. If <enter> is pressed at the “YY X” prompt, “X” will flash, indicating that it can be changed. Pressing <up> or <down> will toggle “X” between “1” (enabled) and “0” (disabled). Pressing <enter> again will save the displayed setting and return you to the non-flashing “YY X” prompt. Pressing <exit> will return you to the “dAy” prompt.

If <enter> is pressed at the “Hour” prompt, the controller will enter the stop time setting routine. The display will show the current four-digit hour and minute setting in 24-hour format. The hour setting will be flashing to indicate that it can be modified. Pressing <up> or <down> will increase or decrease the hour. Pressing <enter> will stop the hour from flashing and cause the minutes to flash, indicating they can be modified. Pressing <up> or <down> will increase or decrease the minutes value. Pressing <enter> again will save the displayed setting and return you to the “Hour” prompt. Pressing <exit> while in editing mode will return you to the “Hour” prompt without saving changes.

- **dLay (Delay Setting)**

The default activity based time delay setting is 30 minutes. “dLay” is only used when EnbX = 2. This setting is used to determine the length of time, before activity is detected in the pattern usage memory, that the conservation mode for the lighting is disabled. It is also the length of time, after no activity is detected in the pattern usage memory, until the lighting shifts to the conservation mode. Note, five blocks of consecutive zeroes are still required in order for this “dLAY” value to be in effect when transitioning to conservation mode. The controller should immediately shift out of conservation mode if activity is sensed. If <enter> is pressed at the “dLay” prompt, the controller will display current delay time setting, “XXX,” where XXX is the interval setting in minutes. Using <up> or <down> will increase or decrease the interval setting by five minutes, from 0 to 995. Pressing <enter> will save the currently displayed setting and return the user to the “dLay” prompt. Pressing <exit> at “dLay” will return the controller to the “Lit” prompt. Press <up> to proceed to the next prompt, “rFrG.”

## SECTION 2: SET-UP AND INSTALLATION



### REFRIGERATION CONTROL MODE

If <enter> is pressed at the “rFrG” prompt the controller will enter the refrigeration control mode. Using <up> or <down>, you can rotate through the various refrigeration control settings (“Enb,” “Strt,” “StoP,” “dEG,” “SEtP,” “Stor,” “dSP,” “dEF,” and “dLAy”). If <exit> is pressed, the controller will return to the “rFrG” prompt. Press <up> to proceed to the next prompt, “bLC1.”

- **Enb (Enable)**

If <enter> is pressed at the “Enb” prompt, the current value of the refrigeration energy conservation enable setting is displayed as “EnbX,” where the X value will be “0” if the energy conservation control is disabled, “1” if the day- and time-based energy conservation control is enabled, or “2” if the activity-based energy conservation control is enabled. While enabled, the cabinet temperature will be allowed to raise to the “Stor” temperature during the programmed time blocks if X = 1 or be controlled by the learned activity if X = 2. Using <up> or <down> will toggle between 0, 1, and 2. Pressing <enter> will save the displayed setting and return you to the non-editable “Enb” prompt. From the “Enb” prompt, use <up> to proceed to the next prompt, “Strt.”

If X=0, The refrigeration unit will run according to the “SEtP” setting.

If X=1, Enabled (on), the refrigeration unit runs when the storage temperature is reached\*. *See note below.*

If X=2, The refrigeration unit will be controlled based on learned activity.

*\*Note: If enabled (set to 1), the cabinet temperature will rise to the “Stor” temperature operated by the timer program, ONLY if the Start and Stop times are set.*

- **Strt (Start Time)**

If <enter> is pressed at the “Strt” prompt, the controller will enter the start energy conservation time setting routine. Upon entry into this routine, the display will show the first of the two start time setting modes, “dAy” or “Hour.” Pressing <up> or <down> will cycle between the two. Pressing <exit> at this point will return to the “Strt” prompt without saving any changes. Use <up> to proceed to the next prompt, “StoP.”

If <enter> is pressed at the “dAy” prompt, the controller will enter the day of the week setting routine. The display will show “YY X”, where “YY” is the day of the week (“SUn,” “non,” “tUE,” “UEd,” “thU,” “Fri,” “SAt,” or “ALL”) and “X” is either “1” or “0.” Pressing <up> or <down> will cycle through the days of the week. If <enter> is pressed at the “YY X” prompt, “X” will flash indicating that it can be changed. Pressing <up> or <down> will toggle “X” between “1” (enabled) and “0” (disabled). Pressing <enter> again will save the displayed setting and return you to the non-flashing “YY X” prompt. Pressing <exit> will return to the “dAy” prompt.

If <enter> is pressed at the “Hour” prompt, the controller will enter the start time setting routine. The display will show the current four-digit hour and minute setting, in 24-hour format. The hour setting will be flashing to indicate that it can be modified. Pressing <up> or <down> will increase or decrease the hour. Pressing <enter> will stop the hour from flashing and cause the minutes to flash, indicating they can be modified. Pressing <up> or <down> will increase or decrease the minutes value. Pressing <enter> again will save the displayed setting and return you to the “Hour” prompt. Pressing <exit> while in editing mode will return to the “Hour” prompt without saving changes.

## SECTION 2: SET-UP AND INSTALLATION

- **StoP (Stop Time)**

If <enter> is pressed at the “StoP” prompt, the controller will enter the stop energy conservation time setting routine. Upon entry into this routine, the display will show the first of the two stop time setting modes, “dAy” or “Hour. Pressing <up> or <down> will cycle between the two. Pressing <exit> at this point will return the controller to the “StoP” prompt without saving any changes. Use <up> to proceed to the next prompt, “dEG.”

If <enter> is pressed at the “dAy” prompt, the controller will enter the day of the week setting routine. The display will show “YY X”, where “YY” is the day of the week (“SUn,” “non,” “tUE,” “UEd,” “thU,” “Fri,” “SAT,” or “ALL”) and “X” is either “1” or “0”. Pressing <up> or <down> will cycle through the days of the week. If <enter> is pressed at the “YY X” prompt, “X” will flash, indicating that it can be changed. Pressing <up> or <down> will toggle “X” between “1” (enabled) and “0” (disabled). Pressing <enter> again will save the displayed setting and return you to the non-flashing “YY X” prompt. Pressing <exit> will return to the “dAy” prompt.

If <enter> is pressed at the “Hour” prompt, the controller will enter the stop time setting routine. The display will show the current four-digit hour and minute setting, in 24-hour format. The hour setting will be flashing to indicate that it can be modified. Pressing <up> or <down> will increase or decrease the hour. Pressing <enter> will stop the hour from flashing and cause the minutes to flash, indicating they can be modified. Pressing <up> or <down> will increase or decrease the minutes value. Pressing <enter> again will save the displayed setting and return you to the “Hour” prompt. Pressing <exit> while in editing mode will return the controller to the “Hour” prompt without saving changes. From “StoP,” pressing <up> will proceed you to the next prompt, “dEG.”

- **dEG (Degrees)**

If <enter> is pressed at the “dEG” prompt, the controller will display “dEGX,” where “X” will be flashing. If X = “F”, the controller is currently in Fahrenheit mode; if X = “C”, the controller is currently in Celsius mode. Pressing <up> or <down> will toggle “X” between “F” and “C.” Pressing <enter> at this point will save the displayed temperature mode and return you to the “dEG” prompt. Pressing <exit> will return you to the “dEG” prompt without saving changes. Use <up> to proceed to the next prompt, “SEtP.”

- **SEtP (Set Point)**

The set point default is 35° F (1.5° C). If <enter> is pressed at the “SEtP” prompt, the controller will display the current set point temperature setting “xx F” or “xx.x C,” depending on the “dEG” setting. Using <up> or <down> will increase or decrease the number by 1° F (0.5° C). Pressing <enter> will save the set point and return you to the “SEtP” prompt. Pressing <exit> will return to the “SEtP” prompt without saving changes. From “SEtP,” press <up> to proceed to the next prompt, “Stor.”

- **Stor (Storage Temperature)**

The default storage temperature will be 60° F (15.5° C). If <enter> is pressed at the “Stor” prompt, the controller will display the current storage temperature setting “xx F” or “xx.x C,” depending on the “dEG” setting. Using <up> or <down> will increase or decrease the number by 1° F (0.5° C), over the range of 32° F (0° C) to 75° F (24° C). Pressing <enter> will save the storage temperature and return you to the “Stor” prompt. Pressing <exit> will return you to the “Stor” prompt without saving changes. From “Stor,” press <up> to proceed to the next prompt, “dSP.”

- **dSP (Display Temperature)**

If <enter> is pressed at the “dSP” prompt, the controller will display “dSPX,” where “X” will be flashing. If X = “1,” the controller will display the temperature immediately following the POS. If X = “0,” the controller will not display the temperature. Pressing <up> or <down> will toggle “X” between “1” and “0.” Pressing <enter> will save the currently displayed setting and return you to the “dSP” prompt. Pressing <exit> will return you to the “dSP” prompt without saving changes. From “dSP,” press <up> to proceed to the next prompt, “dEF.”



## SECTION 2: SET-UP AND INSTALLATION

- **dEF (Defrost Interval)**

The default defrost interval is 4 minutes. This setting determines how long the delay will be between evaporator fan cut-in and compressor cut-in. For example, at the four-minute default setting, when the cabinet reaches the cut-in temperature, the evaporator fan will start up. Four minutes later, the compressor will be turned on, ending the defrost interval. If <enter> is pressed at the “dEF” prompt, the controller will display the current defrost interval setting, “NN,” where the N’s represent the interval setting in minutes. Using <up> or <down> will increase or decrease the interval setting in minutes. Pressing <enter> will save the currently displayed setting and return the controller to the “dEF” prompt. Pressing <exit> will return the controller to the “dEF” prompt without saving changes. From “dEF,” press <up> to proceed to the next prompt, “dLAy.” **Note:** “dEF” is used in conjunction with Energy Star® Tier 2. See “C11” in Configurations Mode for an explanation of Energy Star compliance.
- **dLAY (Delay Setting)**

The default activity based time delay setting is 90 minutes. This setting is used to determine the length of time, prior to activity being detected in the pattern usage memory, that the conservation mode is disabled and the temperature shifts to the cold set-point SEtP. “dLAy” is only used when EnbX = 2. The controller should immediately shift from the storage set-point to the cold set-point if activity is sensed. If <enter> is pressed at the “dLAY” prompt, the controller will display current delay time setting, “XXX,” where XXX is the interval setting in minutes. Using <up> or <down> will increase or decrease the interval setting by five minutes, from 0 to 995. Pressing <enter> will save the currently displayed setting and return the user to the “dLAY” prompt. Pressing <exit> will return to the “dLAY” prompt without saving changes. From “dLAy,” press <exit> to return to the “rFrG” prompt.

**Configuration 2 must be enabled (set to “1”) for the following timer functions to operate. If C2 is set to “0,” these timers and the optional override switch will not function.**



### **BLOCK SELECTION 1 / BLOCK SELECTION 2**

If <enter> is pressed at the “bLCX” prompt (where X = 1 or 2), the controller will enter the selection blocking control mode. Using <up> or <down>, you can cycle through the various selection blocking timer settings (“Enb,” “Strt,” “StoP,” and “SEL”). If <exit> is pressed, the controller will return to the “bLCX” prompt. Use <up> to proceed to the next prompt, “DISC.”

- **Enb (Enable)**

If <enter> is pressed at the “Enb” prompt, the current value of the enable setting is displayed as “EnbX,” where the X value will be “0” if the selection blocking is disabled or “1” if it is enabled. This means that active programmed selections will not be allowed to vend during programmed time blocks and a “No Sale Until xxxx” message will be displayed. The “xxxx” will be replaced with the time vends will be allowed again (12 hour format if using “nA” or “OFF” daylight savings time settings; 24 hour format otherwise). Pressing <up> or <down> will allow the user to toggle “X” between “1” and “0”. Pressing <enter> will save the displayed setting and return you to the non-editable “Enb” prompt. Use <up> to proceed to the next prompt, “Strt.”
- **Strt (Start Time)**

If <enter> is pressed at the “Strt” prompt, the controller will enter the start selection blocking time setting routing. Upon entry into this routine, the display will show the first of the two start time setting modes, “dAy” or “Hour.” Pressing <up> or <down> will cycle between the two. Pressing <exit> at this point will return to the “Strt” prompt without saving any changes. Use <up> to proceed to the next prompt, “StoP.”

## SECTION 2: SET-UP AND INSTALLATION

If <enter> is pressed at the “dAy” prompt, the controller will enter the day of the week setting routine. The display will show “YY X”, where “YY” is the day of the week (“SUn,” “non,” “tUE,” “UEd,” “thU,” “Fri,” “SAt,” or “ALL”) and “X” is either “1” or “0.” Pressing <up> or <down> will cycle through the days of the week. If <enter> is pressed at the “YY X” prompt, “X” will flash indicating that it can be changed. Pressing <up> or <down> will toggle “X” between “1” (enabled) and “0” (disabled). Pressing <enter> again will save the displayed setting and return you to the non-flashing “YY X” prompt. Pressing <exit> will return to the “dAy” prompt.

If <enter> is pressed at the “Hour” prompt, the controller will enter the start time setting routine. The display will show the current four-digit hour and minute setting, in 24-hour format. The hour setting will be flashing to indicate that it can be modified. Pressing <up> or <down> will increase or decrease the hour. Pressing <enter> will stop the hour from flashing and cause the minutes to flash, indicating they can be modified. Pressing <up> or <down> will increase or decrease the minutes value. Pressing <enter> again will save the displayed setting and return you to the “Hour” prompt. Pressing <exit> while in editing mode will return to the “Hour” prompt without saving changes.

- **StoP (Stop Time)**

If <enter> is pressed at the “StoP” prompt, the controller will enter the stop selection blocking time setting routing. Upon entry into this routine, the display will show the first of the two stop time setting modes, “dAy” or “Hour. Pressing <up> or <down> will cycle between the two. Pressing <exit> at this point will return the controller to the “StoP” prompt without saving any changes. Use <up> to proceed to the next prompt, “SEL.”

If <enter> is pressed at the “dAy” prompt, the controller will enter the day of the week setting routine. The display will show “YY X”, where “YY” is the day of the week (“SUn,” “non,” “tUE,” “UEd,” “thU,” “Fri,” “SAt,” or “ALL”) and “X” is either “1” or “0”. Pressing <up> or <down> will cycle through the days of the week. If <enter> is pressed at the “YY X” prompt, “X” will flash, indicating that it can be changed. Pressing <up> or <down> will toggle “X” between “1” (enabled) and “0” (disabled). Pressing <enter> again will save the displayed setting and return you to the non-flashing “YY X” prompt. Pressing <exit> will return to the “dAy” prompt.

If <enter> is pressed at the “Hour” prompt, the controller will enter the stop time setting routine. The display will show the current four-digit hour and minute setting, in 24-hour format. The hour setting will be flashing to indicate that it can be modified. Pressing <up> or <down> will increase or decrease the hour. Pressing <enter> will stop the hour from flashing and cause the minutes to flash, indicating they can be modified. Pressing <up> or <down> will increase or decrease the minutes value. Pressing <enter> again will save the displayed setting and return you to the “Hour” prompt. Pressing <exit> while in editing mode will return the controller to the “Hour” prompt without saving changes.

- **SEL (Blocked Selections)**

If <enter> is pressed at the “SEL” prompt, the controller will display “ALLX,” where “X” indicates whether all selections will be blocked or not. Using <up> or <down> will allow you to cycle through each individual selection. If <enter> is pressed at “NN X,” the display will flash “X” (block status) for the displayed selection (“NN”). Pressing <up> or <down> will toggle “X” between “1” (enabled) or “0” (disabled). When the desired setting is on the display, pressing <enter> will save the setting and return to the selection level, where the block status no longer flashes. If the “ALLX” is set and saved, all the selections will be set at once. Use <exit> to return to the “SEL” prompt. From the “SEL” prompt, use <up> to proceed to the next prompt, “LIt.”

- **LIt (Lighting Control)**

If <enter> is pressed at the “LIt” prompt, the controller will display “LItX,” where “X” indicates whether the lighting control is enabled or not. Pressing <up> or <down> will toggle “X” between “1” (enabled) or “0” (disabled). When the desired setting is on the display, pressing <enter> will save the setting and return to the “LIt” prompt. Use <exit> to return to the “bLC” prompt.

## SECTION 2: SET-UP AND INSTALLATION



### SELECTION DISCOUNTING MODE

If <enter> is pressed at the “dISC” prompt, the controller will enter the discount control mode. Using <up> or <down>, the user can cycle through the various discount control settings (“Enb,” “Strt,” “StoP,” “SEL,” and “LESS”). If <exit> is pressed, the controller will return to the “dISC” prompt. Use <up> to proceed to the next prompt, “OUEr.”

- **Enb (Enable)**

If <enter> is pressed at the “Enb” prompt, the current value of the enable setting is displayed as “EnbX,” where the X value will be “0” if the selection discounting is disabled or “1” if it is enabled. This means that active selections will be discounted by the programmed discount amount during the programmed time blocks. Discounted vend prices of zero or less may be allowed, but no credit will ever be given in return. Pressing <up> or <down> will allow the user to toggle “X” between “1” and “0”. Pressing <enter> will save the displayed setting and return you to the non-editable “Enb” prompt. Use <up> to proceed to the next prompt, “Strt.”

- **StRt (Start Time)**

If <enter> is pressed at the “Strt” prompt, the controller will enter the start discounting time setting routing. Upon entry into this routine, the display will show the first of the two start time setting modes, “dAy” or “Hour.” Pressing <up> or <down> will cycle between the two. Pressing <exit> at this point will return to the “Strt” prompt without saving any changes.

If <enter> is pressed at the “dAy” prompt, the controller will enter the day of the week setting routine. The display will show “YY X”, where “YY” is the day of the week (“SUn,” “non,” “tUE,” “UEd,” “thU,” “Fri,” “SAt,” or “ALL”) and “X” is either “1” or “0”. Pressing <up> or <down> will cycle through the days of the week. If <enter> is pressed at the “YY X” prompt, “X” will flash, indicating that it can be changed. Pressing <up> or <down> will toggle “X” between “1” (enabled) and “0” (disabled). Pressing <enter> again will save the displayed setting and return you to the non-flashing “YY X” prompt. Pressing <exit> will return to the “dAy” prompt.

If <enter> is pressed at the “Hour” prompt, the controller will enter the start time setting routine. The display will show the current four-digit hour and minute setting, in 24-hour format. The hour setting will be flashing to indicate that it can be modified. Pressing <up> or <down> will increase or decrease the hour. Pressing <enter> will stop the hour from flashing and cause the minutes to flash, indicating they can be modified. Pressing <up> or <down> will increase or decrease the minutes value. Pressing <enter> again will save the displayed setting and return you to the “Hour” prompt. Pressing <exit> while in editing mode will return to the “Hour” prompt without saving changes. Use <up> to proceed to the next prompt, “StoP.”

- **StoP (Stop Time)**

If <enter> is pressed at the “StoP” prompt, the controller will enter the stop discounting time setting routing. Upon entry into this routine, the display will show the first of the two stop time setting modes, “dAy” or “Hour.” Pressing <up> or <down> will cycle between the two. Pressing <exit> at this point will return to the “StoP” prompt without saving any changes.

If <enter> is pressed at the “dAy” prompt, the controller will enter the day of the week setting routine. The display will show “YY X”, where “YY” is the day of the week (“SUn,” “non,” “tUE,” “UEd,” “thU,” “Fri,” “SAt,” or “ALL”) and “X” is either “1” or “0”. Pressing <up> or <down> will cycle through the days of the week. If <enter> is pressed at the “YY X” prompt, “X” will flash, indicating that it can be changed. Pressing <up> or <down> will toggle “X” between “1” (enabled) and “0” (disabled). Pressing <enter> again will save the displayed setting and return you to the non-flashing “YY X” prompt. Pressing <exit> will return to the “dAy” prompt.

## SECTION 2: SET-UP AND INSTALLATION

If <enter> is pressed at the “Hour” prompt, the controller will enter the stop time setting routine. The display will show the current four-digit hour and minute setting, in 24-hour format. The hour setting will be flashing to indicate that it can be modified. Pressing <up> or <down> will increase or decrease the hour. Pressing <enter> will stop the hour from flashing and cause the minutes to flash, indicating they can be modified. Pressing <up> or <down> will increase or decrease the minutes value. Pressing <enter> again will save the displayed setting and return you to the “Hour” prompt. Pressing <exit> while in editing mode will return to the “Hour” prompt without saving changes. Use <up> to proceed to the next prompt, “SEL.”

- **SEL (Discount Selections)**

If <enter> is pressed at the “SEL” prompt, the controller will display “NN X”, where “NN” represents the selection number and “X” indicates whether that selection will be discounted or not. Using <up> or <down> will allow you to cycle through each individual selection. If <enter> is pressed at “NN X”, the display will flash “X” (discount status) for the displayed selection. Pressing <up> or <down> will toggle “X” between “1” (enabled) or “0” (disabled). When the desired setting is on the display, pressing <enter> will save that setting and return to the selection level, where the “X” no longer flashes. If the “ALLX” is set and saved, all the selections will be set at once. Use <exit> to return to the “SEL” prompt. Use <up> to proceed to the next prompt, “LESS.”

- **LESS (Less Amount)**

If <enter> is pressed at the “LESS” prompt, the controller will display current four digit discount amount (00.00 – 99.95). Using <up> or <down> will increase or decrease this amount in increments of the least coin tube value. Pressing <enter> will save the setting and return to the “LESS” prompt. Pressing <exit> will return you to the “LESS” prompt without saving any changes. From the “LESS” prompt, use <exit> to return to the “dISC” prompt. (Note: If the discount amount is greater than the sales price for a given selection, the selection will free-vend.)



### MANUAL SWITCH OVERRIDE

If the vender is equipped with a key switch, it can be used to override some of the settings stored for normal operation of the vender. The key switch can be programmed to control one or several features simultaneously. If a feature is enabled in this menu, that feature will override normal machine operation when the switch is activated.

If <enter> is pressed at the “OUEr” prompt the controller will enter the override configuration setting mode by displaying “FrE.” Using <up> or <down> will allow you to cycle through all available override configuration options. If <exit> is pressed at any time during this operation, the controller will return to the “OUEr” prompt. From the “OUEr” prompt, press <up> to proceed to the next prompt, “SdEP.”

The following options can be selected in the override selection level:

- **FrE (Free Vend)**

“FrE” allows all selections to be set for free-vending while the override switch is engaged. If <enter> is pressed at the “FrE” prompt, the controller will enter the free vend override setting. The display will show “FrEX,” where “X” is the current status. Pressing <up> or <down> will cause “X” to toggle between “1” and “0.” When the desired status is displayed, pressing <enter> will save that status and return you to the “FrE” display. If “FrE” is enabled, “FrEE” will be displayed immediately after the POS message.

If X = 0, free vend will be disabled when the key switch is activated.

If X = 1, free vend will be enabled when the key switch is activated.

## SECTION 2: SET-UP AND INSTALLATION

- **Und (Vending Override)**

“Und” blocks the sale of all selections while the override switch is engaged. If <enter> is pressed at the “Und” prompt, the controller will enter the vending override setting. The display will show “UndX,” where “X” is the current status. Pressing <up> or <down> will cause “X” to toggle between “1” and “0.” When the desired status is displayed, pressing <enter> will save that status and return you to the “Und” display. If “Und” is enabled, no selections will be allowed to vend and a “No SALE” message will be displayed.

If X = 0, vending override will be disabled when the key switch is activated.

If X = 1, vending override will be enabled when the key switch is activated.

*Note: If both “FrE” and “Und” are enabled, “Und” will be given priority (no vending will be allowed).*

- **bLC (Selection Blocking Override)**

“bLC” blocks the sale of all selections that are set to “1” in the “SEL” section of “bLC1” and “bLC2” if the override switch is engaged between the “Strt” and “StoP” times. If <enter> is pressed at the “bLC” prompt, the controller will enter the selection blocking override setting. The display will show “bLCX,” where “X” is the current status. Pressing <up> or <down> will cause “X” to toggle between “1” and “0.” When the desired status is displayed, pressing <enter> will save that status and return you to the “bLC” display. If “bLC” is enabled and one of the blocked selections is attempted during the pre-set time, a “No SALE tiL xxxx” message will be displayed (where “xxxx” is the “StoP” time set in the appropriate time block).

If X = 0, selection blocking will be disabled when the key switch is activated.

If X = 1, selection blocking will be enabled when the key switch is activated.

*Note: “bLC” is used in conjunction with “bLCX” programming menus.*

- **dSC (Discount Override)**

“dSC” discounts all selections that are set to “1” in the “SEL” section of “dISC” if the override switch is engaged between the “Strt” and “StoP” times. If <enter> is pressed at the “dSC” prompt, the controller will enter the discount override setting. The display will show “dSCX,” where “X” is the current status. Pressing <up> or <down> will cause “X” to toggle

between “1” and “0.” When the desired status is displayed, pressing <enter> will save that status and return you to the “dSC” display.

If X = 0, discounting will be disabled when the key switch is activated.

If X = 1, discounting will be enabled when the key switch is activated.

*Note: “dSC” is used in conjunction with the “dISC” programming menu.*

- **LIt (Lighting Control Override)**

“LIt” allows the fluorescent lamps to be turned off if the override switch is engaged between the “Strt” and “StoP” times set in the “LIt” mode of the main service menu. If <enter> is pressed at the “LIt” prompt, the controller will enter the lighting control override setting. The display will show “LItX,” where “X” is the current status. Pressing <up> or <down> will cause “X” to toggle between “1” and “0.” When the desired status is displayed, pressing <enter> will save that status and return you to the “LIt” display.

If X = 0, lighting control will be disabled when the key switch is activated.

If X = 1, lighting control will be enabled when the key switch is activated.

*Note: “Lit” is used in conjunction with the “LIt” programming menu.*

- **FrG (Refrigeration Control Override)**

“FrG” allows the refrigeration unit to be turned off if the override switch is engaged between the “Strt” and “StoP” times set in the “rFrG” mode of the main service menu. If <enter> is pressed at the “FrG” prompt, the controller will enter the refrigeration control override setting. The display will show “FrGX,” where “X” is the current status. Pressing <up> or <down> will cause “X” to toggle between “1” and “0.” When the desired status is displayed, pressing <enter> will save that status and return you to the “FrG” display.

If X = 0, refrigeration control will be disabled when the key switch is activated.

If X = 1, refrigeration control will be enabled when the key switch is activated.

*Note: “Lit” is used in conjunction with the “Lit” programming menu.*

## SECTION 2: SET-UP AND INSTALLATION

SdEP

### SELECTION DEPTH SETTING MODE

If <enter> is pressed at the “SdEP” prompt, the controller will enter the by-selection column-depth setting mode by displaying “ALL.” Using <up> or <down> will allow you to cycle through the individual selections. This is the selection level. If <exit> is pressed at any time during this operation, the controller will return to the “SdEP” prompt.

If <enter> is pressed the display will show “ALL” or “NN X”, depending on whether the “ALL” mode is being used or an individual selection is being accessed. “NN” represents the number of the selection, and “X” represents the current column-depth setting of the selection. “X” will be “2” if set to double-depth mode (cans or other small packages) or “1” if set to single-depth mode (most bottles and other long packages). Using <up> or <down> will alternate “X” between “2” and “1.” When the desired setting is on the display, pressing <enter> will save that setting and return to the selection level. Pressing <exit> will return to the selection level without saving. If the “ALL” setting is saved, all individual selections will be set to this depth. From the selection level, press <exit> to return to the “SdEP” prompt. Use <up> to proceed to the next prompt, “rUnd.”

rUnd

### REMOTE VEND MECHANISM ROUTINE

If the <enter> button is activated at the “rUnd” prompt, the controller will enter the universal satellite device control routine. Upon entry into this routine the display will show the first summary level code, “Strt.” Using the <up> or <down> buttons will cycle through the available summary level codes as listed below. Activation of the <enter> button will enter the detail level routines. Activation of the <exit> button while a summary level prompt is displayed will return the controller to the “rUnd” prompt. Use <up> to proceed to the final prompt, “rtn.”

- **Start (Start Time)**

If the <enter> button is activated at the “Strt” prompt, the controller will enter the start time setting routine. Upon entry into this routine the display will show the first summary level code, “dAY.” Using <up> or <down> will cycle through the available summary level codes as listed below. Press <enter> to enter the detail level routines. Pressing <exit> while a summary level prompt is displayed will return the controller to the “Strt” prompt. Pressing <exit> at the “Strt” prompt will return the controller to the “rUnd” prompt.

If <enter> is pressed at the “dAy” prompt, the controller will enter the day of week setting routine. Upon entry into this routine the display will show the current day of the week setting, for example “FriX,” where X will be “1” if the state is active, or “0” if the state is not active. Using <up> or <down> will rotate through “non,” “tUE,” “UEd,” “tHu,” “Fri,” “SAT,” “Sun,” or “ALL.” Pressing <exit> will return the controller to the “day” prompt without making any changes.

If <enter> is pressed at the “Hour” prompt, the controller will enter the start time setting routine. Upon entry into this routine the display will show the current four-digit hour and minute setting, in 24-hour format (0000, midnight, to 2359). The hour setting will be flashing to indicate that it can be edited. Using <up> or <down> will increase or decrease the number. Pressing <enter> will cause the minute setting to begin flashing, indicating that it can now be edited. Using <up> or <down> will increase or decrease the number. Pressing <enter> will save the hour and minute setting and return to the “Hour” prompt. Pressing <exit> will return the controller to the “Hour” prompt without saving any changes.

## SECTION 2: SET-UP AND INSTALLATION

- **StoP (Stop Time)**

If <enter> is pressed at the “StoP” prompt, the controller will enter the start time setting routine. Upon entry into this routine the display will show the first summary level code, “dAY.” Using <up> or <down> will cycle through the available summary level codes as listed below. Pressing <enter> will enter the detail level routines. Pressing <exit> while a summary level prompt is displayed will return the controller to the “StoP” prompt. Pressing <exit> at the “StoP” prompt will return the controller to the “rUnd” prompt.

If <enter> is pressed at the “dAY” prompt, the controller will enter the day of week setting routine. Upon entry into this routine the display will show the current day of the week setting, for example “FriX,” where X will be “1” if the state is active, or “0” if the state is not active. Using <up> or <down> will rotate through “non,” “tUE,” “UEd,” “tHu,” “Fri,” “SAt,” “Sun,” or “ALL.” Pressing <exit> will return the controller to the “day” prompt without making any changes.

If <enter> is pressed at the “Hour” prompt, the controller will enter the stop time setting routine. Upon entry into this routine the display will show the current four-digit hour and minute setting, in 24-hour format (0000, midnight, to 2359). The hour setting will be flashing to indicate that it can be edited. Using <up> or <down> will increase or decrease the number. Pressing <enter> will cause the minute setting to begin flashing, indicating that it can now be edited. Using <up> or <down> will increase or decrease the number. Pressing <enter> will save the hour and minute setting and return to the “Hour” prompt. Pressing <exit> will return the controller to the “Hour” prompt without saving any changes.

- **SEL (Selections)**

If <enter> is pressed at the “SEL” prompt, the controller will enter the selection setting routine. Upon entry into this routine the display will show the current setting for selection one as “01 X,” where X is “1” if the state is active or “0” if the state is not active. Using <up> or <down> will rotate through the valid selections or “ALL.” Pressing <exit> will return the controller to the “SEL” prompt without making any changes.

- **rAtE (Rate)**

If <enter> is pressed at the “rAtE” prompt, the controller will enter the universal satellite device vend rate routine. Upon entry into this routine the display will show the current vend rate (0 - 255). Using <up> or <down> will increase or decrease the number in single-digit increments. A rate of “0” will disable the universal satellite device vending. All active selection vends (from above menu), regardless of selection, should be counted in this vend rate. Pressing <enter> will save the setting and return to the “rAtE” prompt. From “rAtE,” press <exit> to return to the code level.



### RETURN TO SALES

If <enter> is pressed at the “rtn” prompt, the controller will return to the open-door mode.

## SECTION 2: SET-UP AND INSTALLATION

### External Menu

Access the External Menu by entering your 4-digit password when the main door is closed (see “PrEU” in the “Internal [Service] Menu” section).

*Note: Sales counters and cash counters can not be reset and error codes can not be cleared in the External Menu.*

**SALE**

#### SALES COUNTERS

If the external preview password is correctly entered, the display will show “SALE.” If <enter> is pressed at the “SALE” prompt, the controller will enter the non-resettable vend display mode by displaying “SALE” / “XXXX” / “XXXX,” where the X’s will represent total number of all paid vends over the life of the vender’s control board. If the sales amount is less than five digits long, the upper four-digit set is not displayed. Using <up> or <down> will cycle through each selection as “SLNN” / “XXXX” / “XXXX,” where the N’s represent the appropriate selection number and the X’s represent the vend count for that selection since last reset. If <exit> is pressed at any time during this operation, the controller will return to the code level. Press the <up> button to proceed to the next prompt, “CASH.”

**CASH**

#### CASH COUNTERS

If <enter> is pressed at the “CASH” prompt, the controller will enter the non-resettable cash display mode by displaying “CASH” / “XXXX” / “XX.XX,” where the X’s will represent total cash over the life of the vender’s control board. A decimal point will be displayed in the appropriate position with the lower four digits. If the cash amount is less than five digits long, the upper four-digit set is not displayed. Using <up> or <down> will cycle through each selection as “CANN” / “XXXX” / “XX.XX,” where the N’s represent the appropriate selection number and the X’s represent the cash count for that selection since last reset. If <exit> is pressed at any time during this operation, the controller will return to the code level. Press the <up> button to proceed to the next prompt, “Error.”

**Error**

#### ERROR CODES

If <enter> is pressed at the “Error” prompt, the controller will enter the error display mode. If no errors have occurred since the last error reset, the display will show “nonE.” If an error has been detected since the last error reset, the display will show the first summary error code that has occurred, such as “UEnd,” which would indicate a vend error. Pressing <up> or <down> will allow you to cycle through all of the summary error codes that are present. Pressing <enter> at the displayed summary error code will allow you to view the detailed error codes beneath the summary error heading. Pressing <up> or <down> at this point will allow you to cycle through all of the detailed error codes that are present beneath the summary error code. If the <exit> button is pressed at anytime during this operation, the controller will return to the “Error” prompt. Press the <up> button to proceed to the next prompt, “rtn.”

*For further details on reading error codes, see “Error” in the “Internal [Service] Menu” section.*

**rtn**

#### RETURN TO SALES

If <enter> is pressed at the “rtn” prompt, the controller will return to the sales mode.



## SECTION 3: VENDER COMPONENT EXPLANATION

### Vender Controller

#### (Figure 3.0)

The vender controller is the focal point of all vender operations. Power for the control board is provided by the low voltage transformer. The controller board processes information from input devices such as selection switches, door switch, etc., and issues instructions to output devices such as the digital display, vend motor, etc. Devices such as the coin changer, banknote acceptor and hand-held computer communicate both ways with the controller.

#### THE CONTROLLER RECEIVES INFORMATION FROM:

- Selection Switches
- Home Sensor
- Delivery Chute Sensor
- Door Switch
- Temperature Sensor (optional)

#### THE CONTROLLER ISSUES INSTRUCTIONS TO:

- Vend Motor
- Digital Display

#### THE CONTROLLER COMMUNICATES BOTH WAYS WITH:

- Encoder
- Coin Changer
- Banknote Acceptor
- Hand Held Computer
- Debit Card Reader

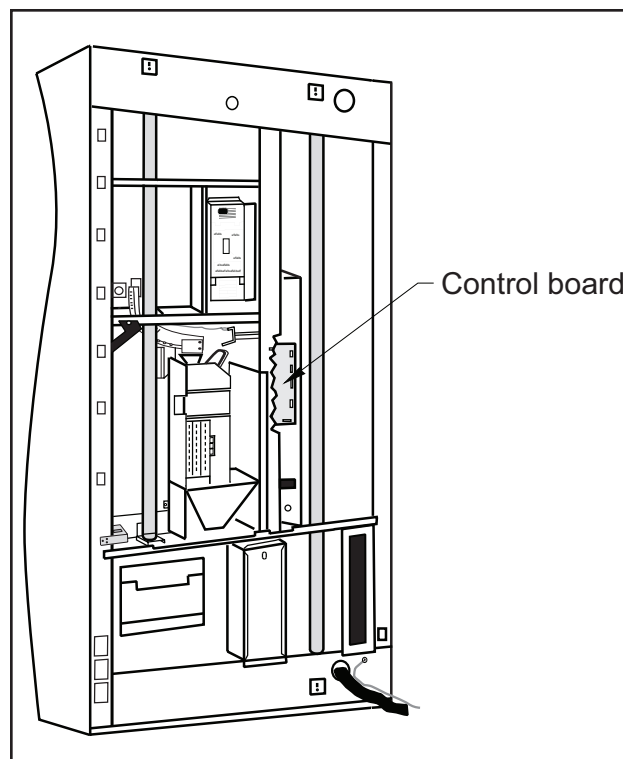

Figure 3.0

### Digital Display (Figure 3.1)

The digital display is located on the vender door next to the coin inlet. The digital display receives its instructions from the vender controller.

In the sales mode, the digital display will display a greeting when the machine is not in use. In the sales mode when the G-III is being used, the digital display will show the accumulated credit when the customer deposits money; the amount of change to be paid back on an over deposit; and the sales price of the selection when selected.

*NOTE: When vender is set in the single-price mode, the vend price will be displayed with the greeting. In the service mode, the digital display is used for diagnostics, vender set-up and MIS information (see "Four-Button Programming" section of this manual).*

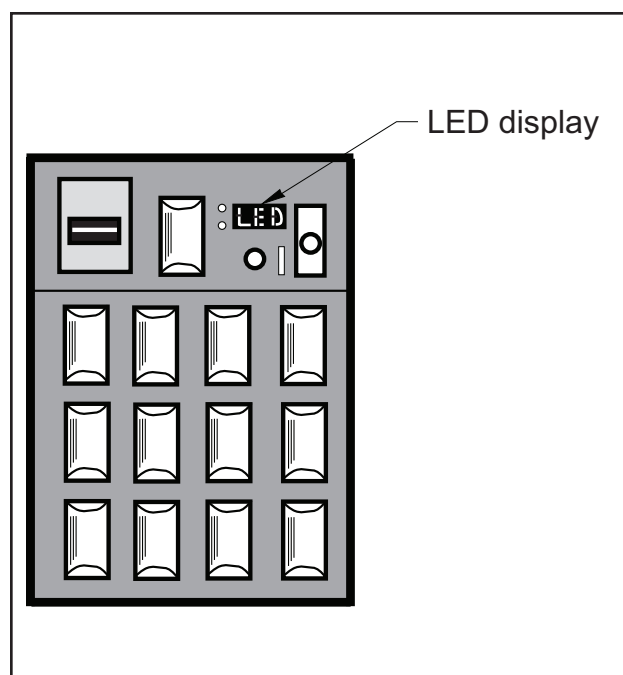

Figure 3.1

# SECTION 3: VENDER COMPONENT EXPLANATION

## Door Switch

The vender door switch is mounted to the lower right side of the vender's door and is actuated by the door each time it is opened or closed (see Figure 3.3). The following functions are performed each time the vender door is closed:

1. Clears any column's sold-out condition;
2. Scrolls E-Prom's revision number 67121-X;
3. If door switch reset is enabled (see "Con"), the resettable MIS counters may be reset, upon reading any selection's counts; and
4. Starts the refrigeration unit after an approximate 5 to 8 minute delay (after door switch is pressed).

*Note:* The door switch is mounted to the lower right side of the vender cabinet on models built prior to P.O. 1521.

## Delivery Chute Sensor

The delivery chute sensor mounted on the bottom of the delivery chute signals the controller when a product is delivered.

## Low Voltage Transformer

The step-down transformer has a secondary winding which produces 24-volt AC output. The transformer works in conjunction with an external fuse which protects the vender in the event of a short in the secondary circuit.

A power supply located on the vender controller changes the 24-volt transformer output to direct current.

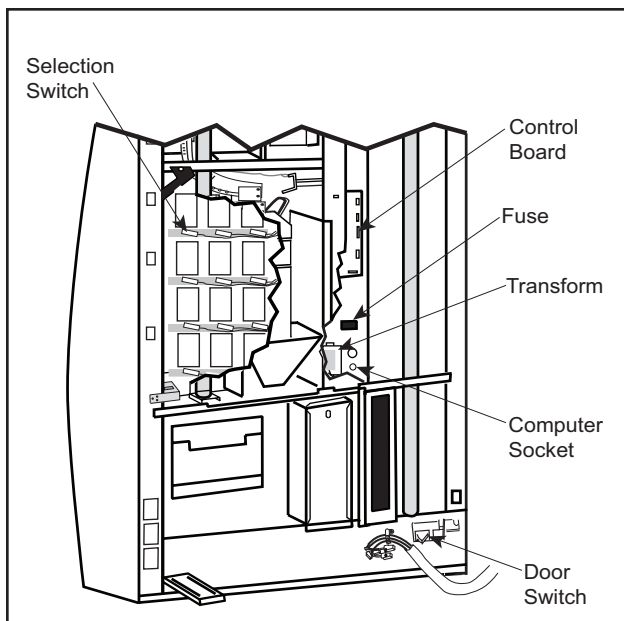

Figure 3.3

## Selection Switches

The selection switches signal the vender controller when a selection is made (see Figure 3.3). These switches are also used to program all vender functions (see "Four-Button Programming" section of this manual).

## Coin Changer

The coin changer determines the validity and value of each coin that is inserted into the vender and sends the coin information to the vender controller. The coin changer also continuously informs the vender controller if coins are available in the change tubes to be used for change payout. All change tube status and credit information is accumulated in the vender controller which controls all vend and payout functions as well as illumination of the vender's correct change light.

*NOTE:* For detailed changer information, refer to separate operation and service manual for coin changer.

## Banknote Acceptor

The banknote acceptor determines the validity and value of each note that is inserted into the vender and sends the banknote information to the vender controller.

*NOTE:* For detailed banknote acceptor information, refer to separate operation and service manual for banknote acceptor.

## Debit Card Reader

The debit card reader is the newest credit acceptance device in the vending industry. The G-III Vender with Four-Button Programming is equipped to utilize the card reader system.

Customers purchase "credit cards" for use in card reader equipped vending machines. These cards are either magnetically encoded with an amount of credit or contain a computer chip which stores the amount of credit. Upon insertion into the card reader, the controller determines if there is enough credit on the card to make the requested purchase. If there is enough credit available, the product is vended and the vend price is subtracted from the amount of credit on the card.

*NOTE:* For detailed debit card reader information, refer to separate operation and service manual for debit card reader.

## SECTION 3: VENDER COMPONENT EXPLANATION

### Vend Rack Assembly

The vend rack assembly, located in the cooling compartment of the vender, is composed of twelve product columns; six located in the front (columns one through six) and six in the rear (columns seven through twelve). Both front and rear columns are double-depth columns that can be adjusted to single-depth to accommodate packages other than 355 mL cans. Different package types *cannot* be mixed within the same column.

Each column has an individual vend mechanism consisting of a rotating pivot, which is held in place by a spring-loaded release lever. On the opposite side of the column are the product stops, both of which are adjustable to vary the clearance through the mechanism for various diameter packages. These parts are mounted at the bottom of each column, and supported by rods through the vender's centre support.

Beneath the rack and mounted to the left wall is a single

vend motor and home sensor assembly. Connected to the motor's drive sprocket and running below the centre support is the drive chain and lever actuator assembly.

See "Vend Sequence" section for a complete description of the vend operation.

### Vend Rack Components

**PIVOT:** Located directly below each of the columns. Product in the column is retained between this pivot and the product stops. Rotation of the pivot allows the bottom package to dispense.

**ADJUSTABLE PRODUCT STOPS:** Two adjustable product stops, one long and one short, are located in each column. Both the long and short product stops can be adjusted to vend either large diameter packages or small

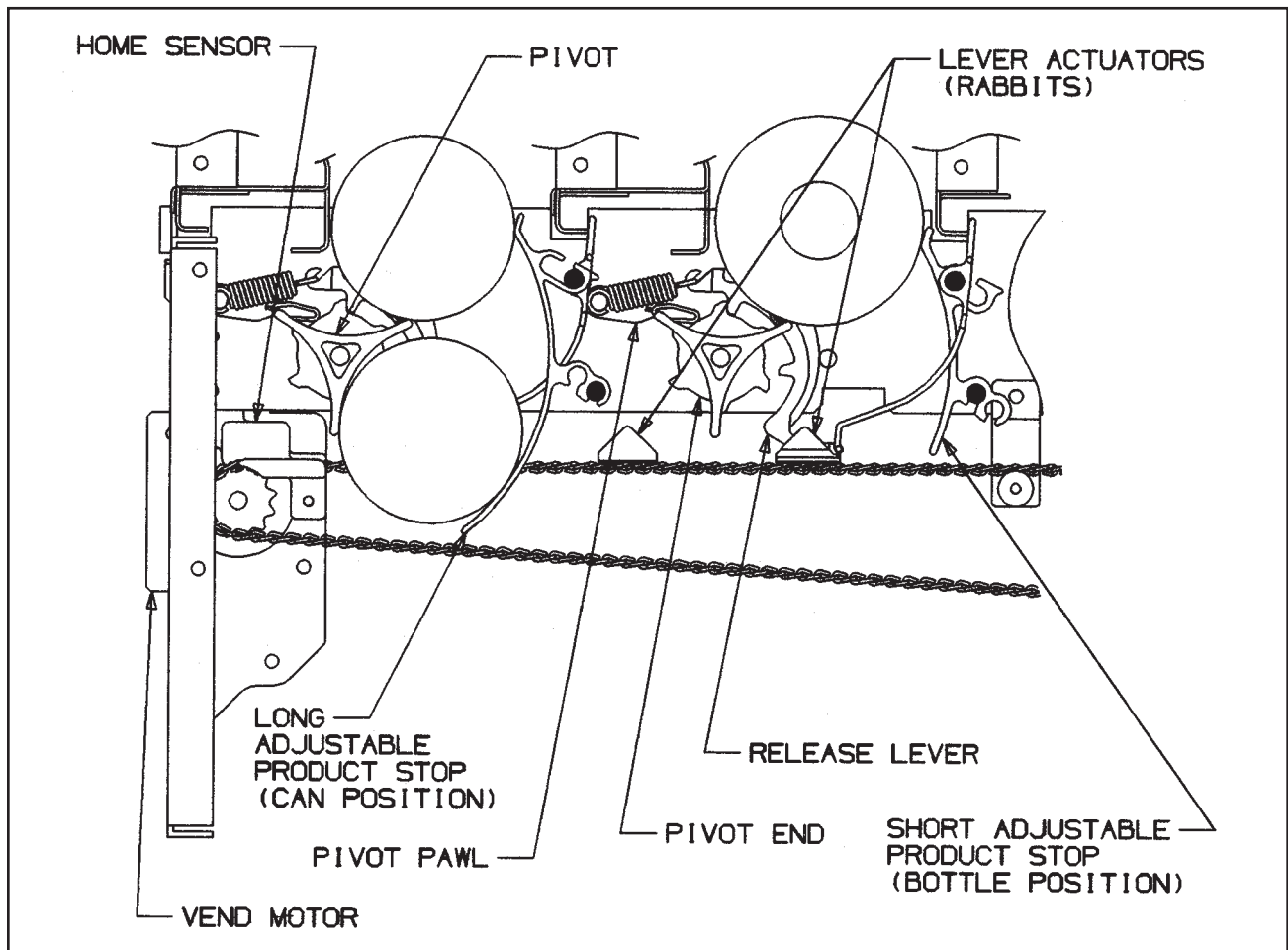

Figure 3.5

## SECTION 3: VENDER COMPONENT EXPLANATION

diameter packages. In any given column, *both the long and the short adjustable product stops must be set to the same diameter position* (i.e. when vending 355 mL cans from a column, both the long and the short adjustable product stops must be set to the “small” package position). For adjustment, see “Setting the Adjustable Product Stops” section of this manual.

**PIVOT END AND RELEASE LEVER:** A geared pivot end is inserted in the pivot. Its gear teeth engage with the teeth of the spring-loaded release lever thereby locking the pivot assembly until the release lever is pulled by the motor driven lever actuator.

**PIVOT PAWL:** A pivot pawl is used on each column’s vend mechanism to reduce the backlash (“play”) between the pivot assembly and the release lever. Pivot pawls are mounted behind the release lever springs.

**ANTI-TILT SPRING:** Prevents lowest can on fixed product stop from free vending if the vender is tilted or shaken by vandals.

**VEND MOTOR ASSEMBLY:** This assembly is comprised of a vend motor and electronic encoder. These are controlled by the vender’s electronic controller. The encoder confirms the motor’s positioning of the lever actuator.

**HOME SENSOR:** The home sensor is mounted directly above the vend motor sprocket on the vend motor mounting bracket. It senses the lever actuator, using this information to signal the controller that the lever actuator has reached the “home” position.

**DRIVE CHAIN AND LEVER ACTUATOR:** Attached to the drive chain are the two sets of lever actuators. The vend motor accurately positions the lever actuator to strike the appropriate release lever.

**IDLER BRACKET ASSEMBLY:** Provides proper tensioning for the chain assembly.

**CHAIN STABILISER:** Provides support for the upper run of the chain assembly.

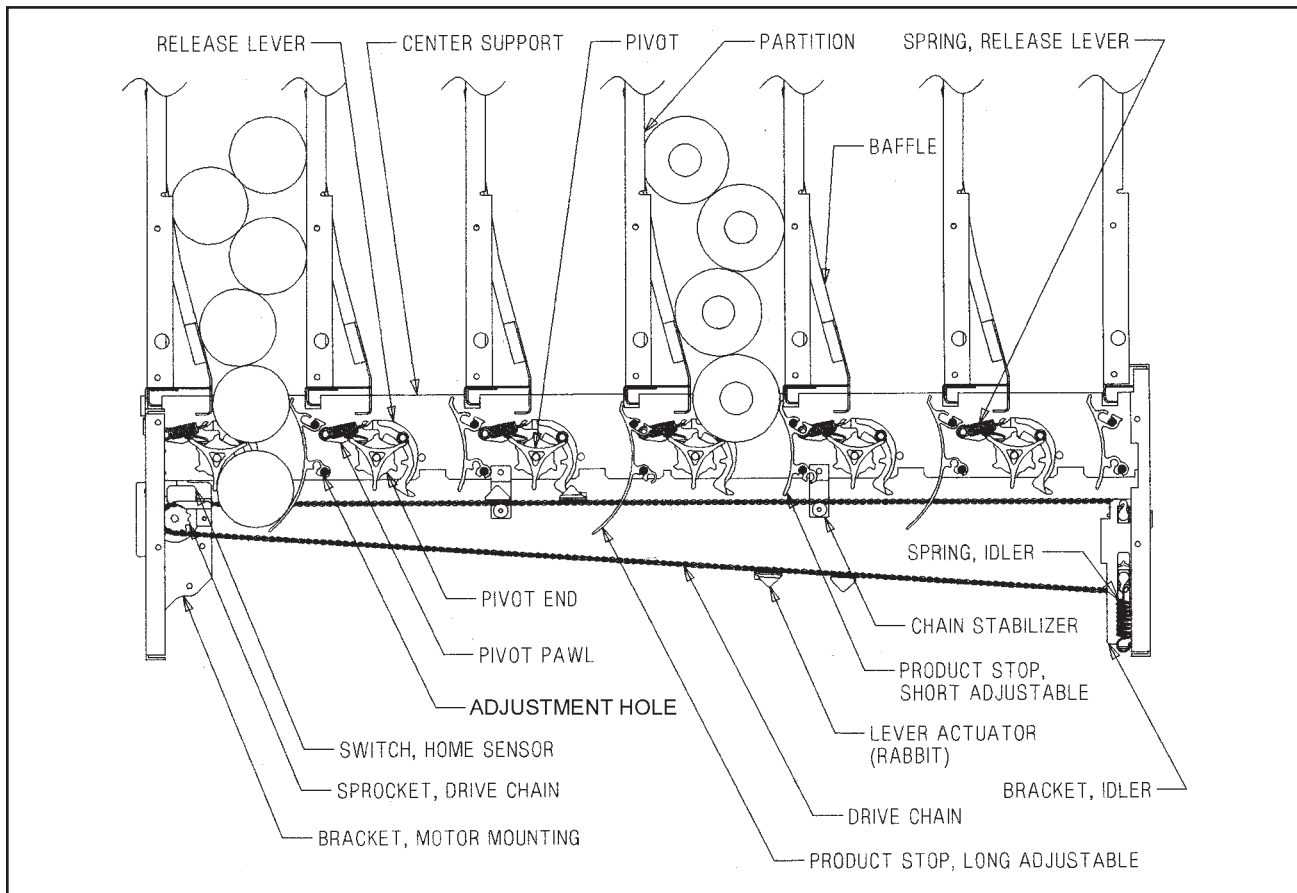

Figure 3.7

## SECTION 3: VENDER COMPONENT EXPLANATION

### Refrigeration System Component Explanation

**COMPRESSOR/COMPRESSOR MOTOR:** The compressor/compressor motor is a hermetically sealed unit located beneath (outside) the cooling compartment. The compressor is a pump, driven by the compressor motor, which draws low pressure vapour (refrigerant) from the evaporator coil, compresses and forces it into the condenser under high pressure. The motor is started and controlled by the temperature control.

**STARTING RELAY:** The starting relay is mounted on the side of the compressor housing. The compressor motor has two windings, a start and a run winding. To give the motor additional torque when it first starts, the starting relay switches in the additional start winding. After the motor gets up to speed the relay opens the start winding and the motor continues off the run winding.

**THERMAL OVERLOAD:** The thermal overload is a heat sensitive device mounted on the side of the compressor housing. If the compressor motor gets too hot or draws an excessive amount of current, the thermal overload will open, breaking both the start and run circuits of the motor. After the compressor cools to a safe operating temperature, the thermal overload will close allowing the compressor and condenser fan motors to restart.

**CONDENSER:** The condenser coil is located beneath (outside) the cooling compartment next to the compressor/compressor motor. The condenser removes heat from the high pressure vapour discharged from the compressor and condenses it to a high pressure liquid.

**CONDENSER FAN MOTOR:** The condenser fan motor, located beneath the cooling compartment, is a forced air device that uses outside ambient air to cool the surface of the condenser coil. The condenser fan motor runs while the compressor runs.

**EVAPORATOR:** The evaporator coil is located in the cooling compartment. As low pressure vapour passes through the evaporator coil, it absorbs and removes heat from the compartment.

**EVAPORATOR FAN MOTORS:** The evaporator fan motor is a forced air device that circulates air throughout the cooling compartment and over the heat exchange surface of the evaporator coil. The evaporator fan motor runs continuously.

**NOTE:** The Condenser and Evaporator Coils have aluminium fins attached to effectively increase their heat exchange surfaces.

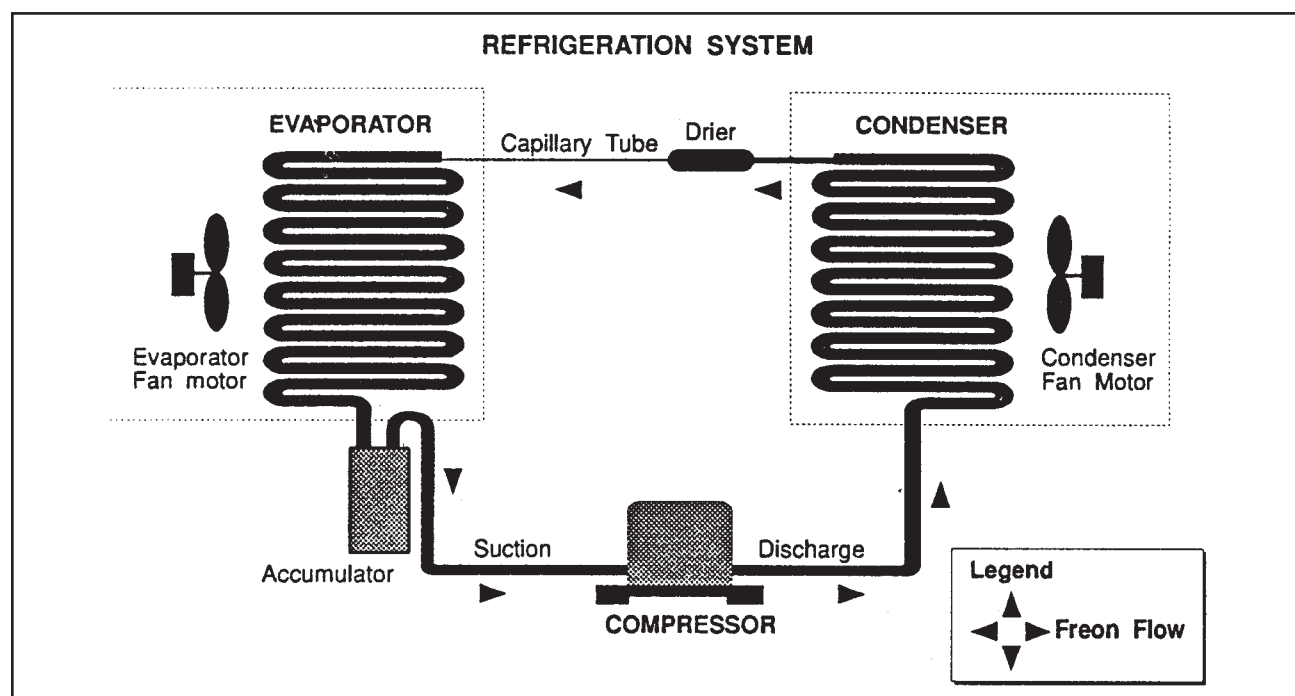

Figure 3.8

## SECTION 3: VENDER COMPONENT EXPLANATION

---

**CAPILLARY TUBE:** The capillary tube is located in the refrigerant line, between the condenser and evaporator coils. The small diameter tube is used as a metering device to control the flow of liquid refrigerant to the evaporator coil. This creates a low pressure causing the refrigerant to vapourise and absorb heat as it passes through the evaporator.

**DRIER:** The drier is located in the refrigerant line between the capillary tube and condenser. It traps and removes moisture from the refrigeration system while allowing oil and refrigerant to pass through the system.

**ACCUMULATOR:** The accumulator is located in the refrigerant line between the evaporator coil and compressor. The accumulator traps any liquid refrigerant which did not vapourise before it reaches the compressor.

**COOLING COMPARTMENT:** The cooling compartment is the sealed area of the vender that holds the product for delivery. This area is designed to allow free flowing air to circulate throughout the product.

### The Electronic Refrigeration Cycle

1. The temperature sensor (electronic thermometer) informs the board of the cabinet temperature. The board's function is to interpret the temperature and turn on/off according to the program setting for refrigeration.
2. The control board activates the relay, turning on the compressor and condenser fan motors. The control board also deactivates the relay, turning off the compressor and condenser fan motors.
3. The compressor circulates refrigerant throughout the system by pulling low pressure refrigerant vapour from the evaporator coil, compressing it and forcing it into the condenser coil.
4. The condenser, aided by the condenser fan motor, removes heat from the refrigerant as it flows through the condenser coil and releases it to the outside environment. The dropping of the refrigerant temperature changes the vapour to a liquid.
5. The capillary tube controls the amount of refrigerant released to the evaporator coil.
6. The evaporator coil allows the vapourised refrigerant to absorb heat from the cooling compartment as it flows through the coil.
7. The falling temperature in the cooling compartment is caused by the continual circulation of refrigerant through the system, removing heat from the cooling compartment and transporting it to the outside environment.

*Note: After the door is closed, there will be a 5-8 minute delay before the refrigeration system will come on.*

## SECTION 4: VEND SEQUENCE OF OPERATION

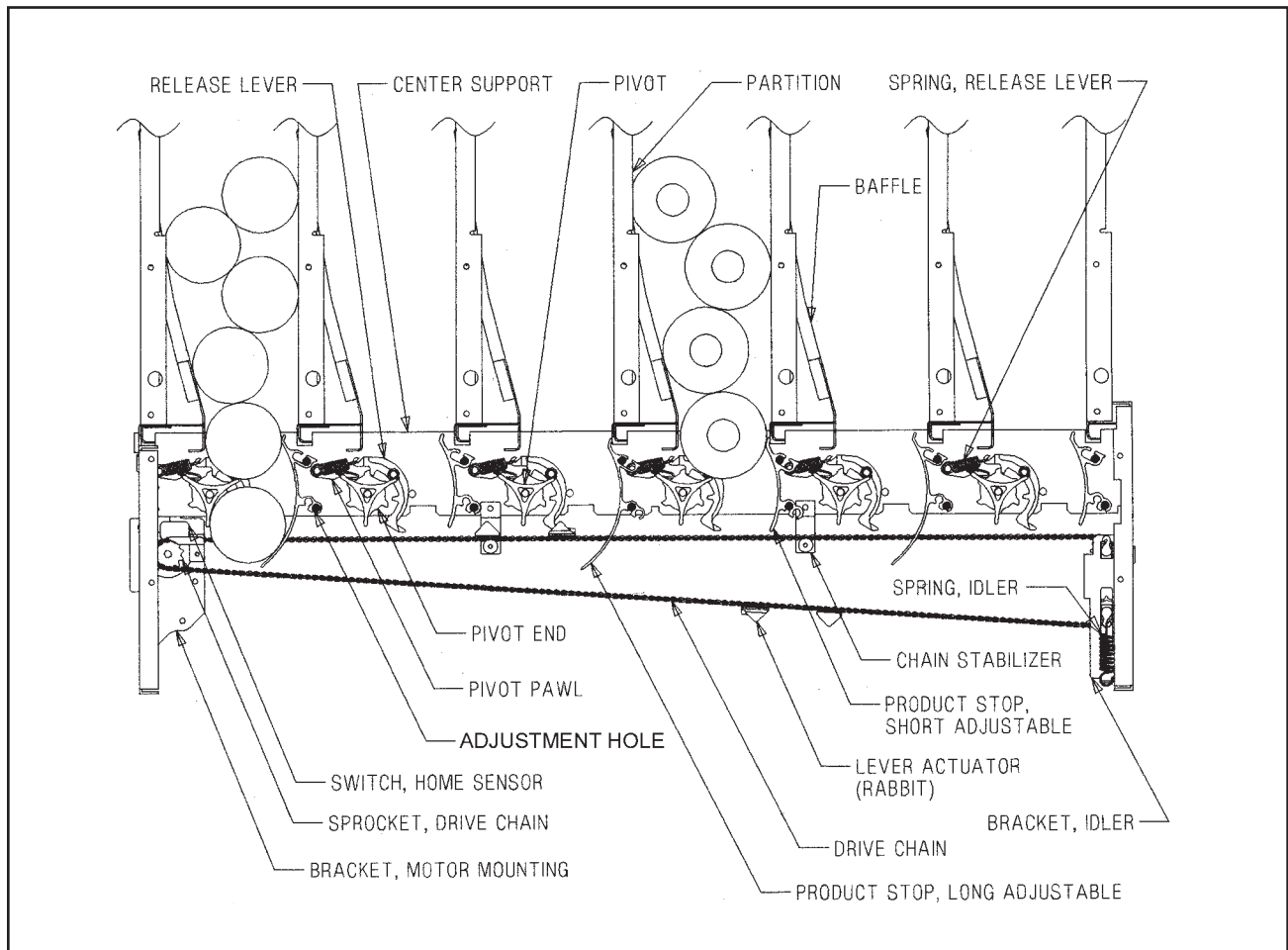

Figure 4.1

### Vend Sequence (Figure 4.1)

**NOTE:** For proper operation, the vender must have several packages in each column. The "Correct Change Only" light will be on if a coin changer is present and sufficient coins are not in the tubes.

1. Credit inserted by the customer (coins, banknotes, debit card) is registered by the controller. A customer can only make a selection after sufficient credit has been inserted to satisfy the sales price setting.

**NOTE:** At any time prior to reaching a vend price, a customer may press the coin release lever on the outside of the vender, cancelling credit and escrowing all inserted money. If a banknote or cashbox coin is inserted, this escrow is disabled. See "C-8 = Escrow Rule #1" for additional information.

2. When the customer presses a selection switch, the controller senses a selection has been made and immediately compares the amount of money validated to the sale price of the selected product.
3. If the amount of money credited is the same or exceeds the sales price setting, the controller directs the vend motor to move the chain (clockwise rotation) to position the lever actuator to the vend position of the selected column.
4. After the position is verified by the encoder, the vend motor is directed to reverse direction (counter-clockwise rotation). The chain drives the lever actuator ("rabbit") to engage and activate the release lever.

## SECTION 4: VEND SEQUENCE OF OPERATION

5. The upper tooth on the release lever disengages the pivot end, allowing the pivot assembly to rotate one increment. At that time, the lower tooth engages the pivot end, preventing further rotation.
6. When the vend motor again reverses (clockwise rotation), the lever actuator pulls away from the release lever allowing the pivot to complete its rotation. It is at this point that double-depth product (e.g. a 355 mL can) is released to the customer. The lever actuator strikes an additional time (two times total) for single-depth product (e.g. 600 mL bottles).
7. The lever actuator (“rabbit”) continues running in a clockwise rotation until the forward one of the two rabbits reaches the home position.
8. A delivery sensor on the bottom of the delivery chute indicates a product was delivered and signals the controller to reset and initiate a payback of change if too much money was inserted.

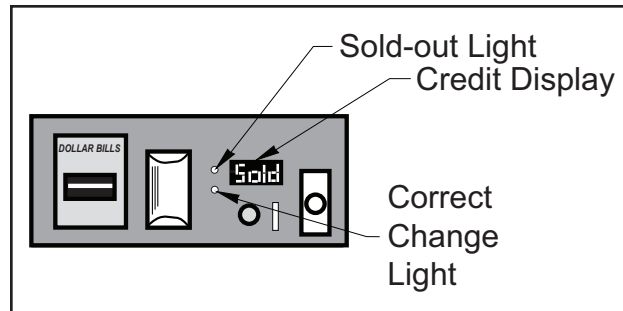

Figure 4.2

### Column Sequencing

If a selection has multiple columns assigned to it, the same column is vended each time the selection button is pressed until the number of times vended is equal to the depth of the column. Then, that selection proceeds to the next column assigned. This is to allow the columns to vend evenly.

### Sold Out

If the product selected is sold out, the digital display will indicate “SOLD OUT” and flash the “SOLD OUT” lamp, signalling the customer to make another selection or push the coin return lever for a full refund. The “SOLD OUT” lamp will continue to flash until a successful vend is completed.

If the vender is totally sold out of product, illumination of the “SOLD OUT” lamp and the “SOLD OUT” message on the digital display will be continuous. No money will be accepted into the vender in a total sold out condition.



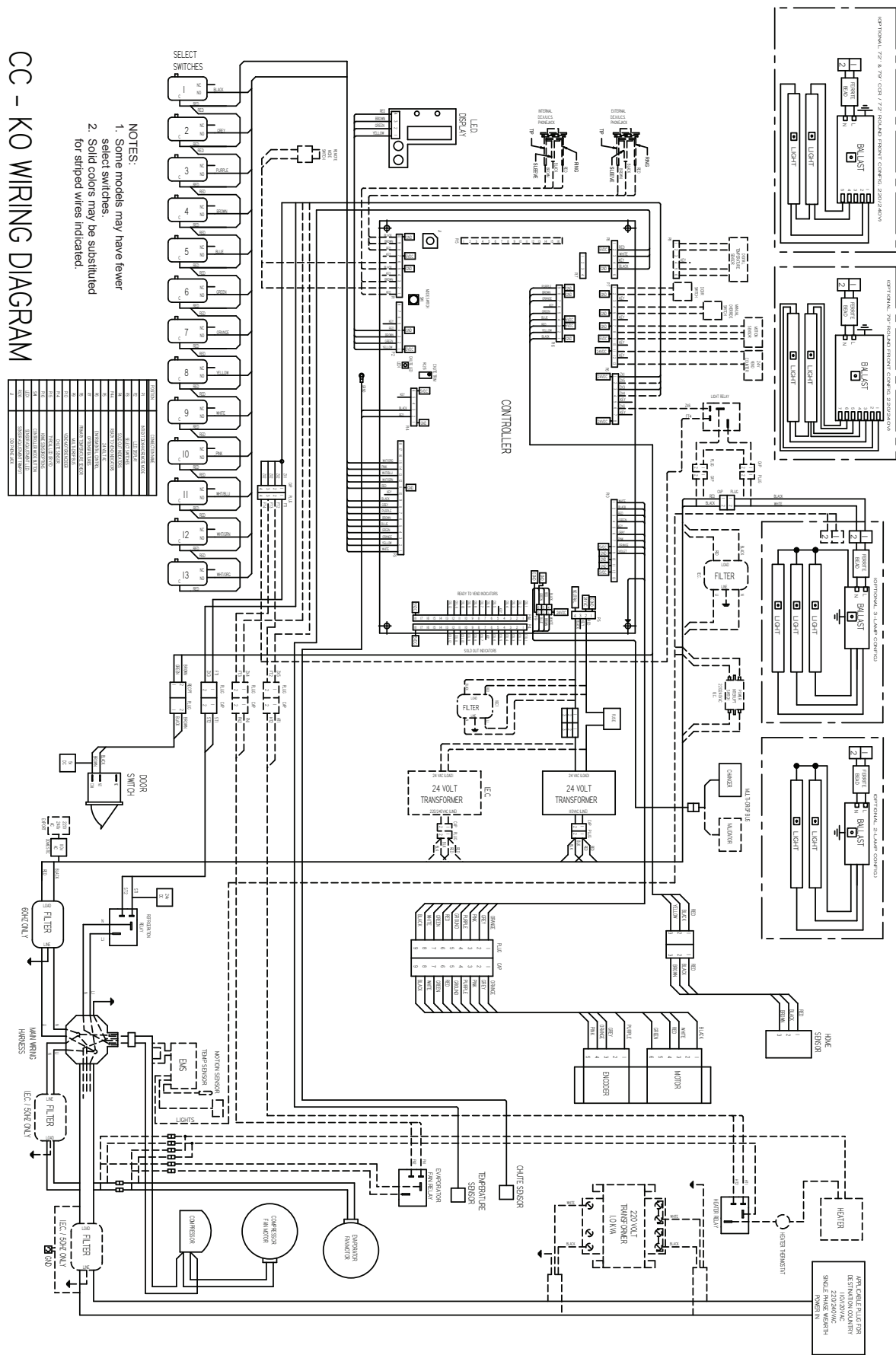

- NOTES:**
1. Some models may have fewer select switches.
  2. Solid colors may be substituted for striped wires indicated.

**CC - KO WIRING DIAGRAM**

WIRE COLOR	WIRE NUMBER	WIRE FUNCTION
RED	1	SELECT SWITCH 1
BROWN	2	SELECT SWITCH 2
BLACK	3	SELECT SWITCH 3
BLACK	4	SELECT SWITCH 4
BLACK	5	SELECT SWITCH 5
BLACK	6	SELECT SWITCH 6
BLACK	7	SELECT SWITCH 7
BLACK	8	SELECT SWITCH 8
BLACK	9	SELECT SWITCH 9
BLACK	10	SELECT SWITCH 10
BLACK	11	SELECT SWITCH 11
BLACK	12	SELECT SWITCH 12
BLACK	13	SELECT SWITCH 13
BLACK	14	SELECT SWITCH 14
BLACK	15	SELECT SWITCH 15
BLACK	16	SELECT SWITCH 16
BLACK	17	SELECT SWITCH 17
BLACK	18	SELECT SWITCH 18
BLACK	19	SELECT SWITCH 19
BLACK	20	SELECT SWITCH 20
BLACK	21	SELECT SWITCH 21
BLACK	22	SELECT SWITCH 22
BLACK	23	SELECT SWITCH 23
BLACK	24	SELECT SWITCH 24
BLACK	25	SELECT SWITCH 25
BLACK	26	SELECT SWITCH 26
BLACK	27	SELECT SWITCH 27
BLACK	28	SELECT SWITCH 28
BLACK	29	SELECT SWITCH 29
BLACK	30	SELECT SWITCH 30
BLACK	31	SELECT SWITCH 31
BLACK	32	SELECT SWITCH 32
BLACK	33	SELECT SWITCH 33
BLACK	34	SELECT SWITCH 34
BLACK	35	SELECT SWITCH 35
BLACK	36	SELECT SWITCH 36
BLACK	37	SELECT SWITCH 37
BLACK	38	SELECT SWITCH 38
BLACK	39	SELECT SWITCH 39
BLACK	40	SELECT SWITCH 40
BLACK	41	SELECT SWITCH 41
BLACK	42	SELECT SWITCH 42
BLACK	43	SELECT SWITCH 43
BLACK	44	SELECT SWITCH 44
BLACK	45	SELECT SWITCH 45
BLACK	46	SELECT SWITCH 46
BLACK	47	SELECT SWITCH 47
BLACK	48	SELECT SWITCH 48
BLACK	49	SELECT SWITCH 49
BLACK	50	SELECT SWITCH 50
BLACK	51	SELECT SWITCH 51
BLACK	52	SELECT SWITCH 52
BLACK	53	SELECT SWITCH 53
BLACK	54	SELECT SWITCH 54
BLACK	55	SELECT SWITCH 55
BLACK	56	SELECT SWITCH 56
BLACK	57	SELECT SWITCH 57
BLACK	58	SELECT SWITCH 58
BLACK	59	SELECT SWITCH 59
BLACK	60	SELECT SWITCH 60
BLACK	61	SELECT SWITCH 61
BLACK	62	SELECT SWITCH 62
BLACK	63	SELECT SWITCH 63
BLACK	64	SELECT SWITCH 64
BLACK	65	SELECT SWITCH 65
BLACK	66	SELECT SWITCH 66
BLACK	67	SELECT SWITCH 67
BLACK	68	SELECT SWITCH 68
BLACK	69	SELECT SWITCH 69
BLACK	70	SELECT SWITCH 70
BLACK	71	SELECT SWITCH 71
BLACK	72	SELECT SWITCH 72
BLACK	73	SELECT SWITCH 73
BLACK	74	SELECT SWITCH 74
BLACK	75	SELECT SWITCH 75
BLACK	76	SELECT SWITCH 76
BLACK	77	SELECT SWITCH 77
BLACK	78	SELECT SWITCH 78
BLACK	79	SELECT SWITCH 79
BLACK	80	SELECT SWITCH 80
BLACK	81	SELECT SWITCH 81
BLACK	82	SELECT SWITCH 82
BLACK	83	SELECT SWITCH 83
BLACK	84	SELECT SWITCH 84
BLACK	85	SELECT SWITCH 85
BLACK	86	SELECT SWITCH 86
BLACK	87	SELECT SWITCH 87
BLACK	88	SELECT SWITCH 88
BLACK	89	SELECT SWITCH 89
BLACK	90	SELECT SWITCH 90
BLACK	91	SELECT SWITCH 91
BLACK	92	SELECT SWITCH 92
BLACK	93	SELECT SWITCH 93
BLACK	94	SELECT SWITCH 94
BLACK	95	SELECT SWITCH 95
BLACK	96	SELECT SWITCH 96
BLACK	97	SELECT SWITCH 97
BLACK	98	SELECT SWITCH 98
BLACK	99	SELECT SWITCH 99
BLACK	100	SELECT SWITCH 100

# SECTION 5: MAINTENANCE

## KO CONTROLLER BOARD LAYOUT

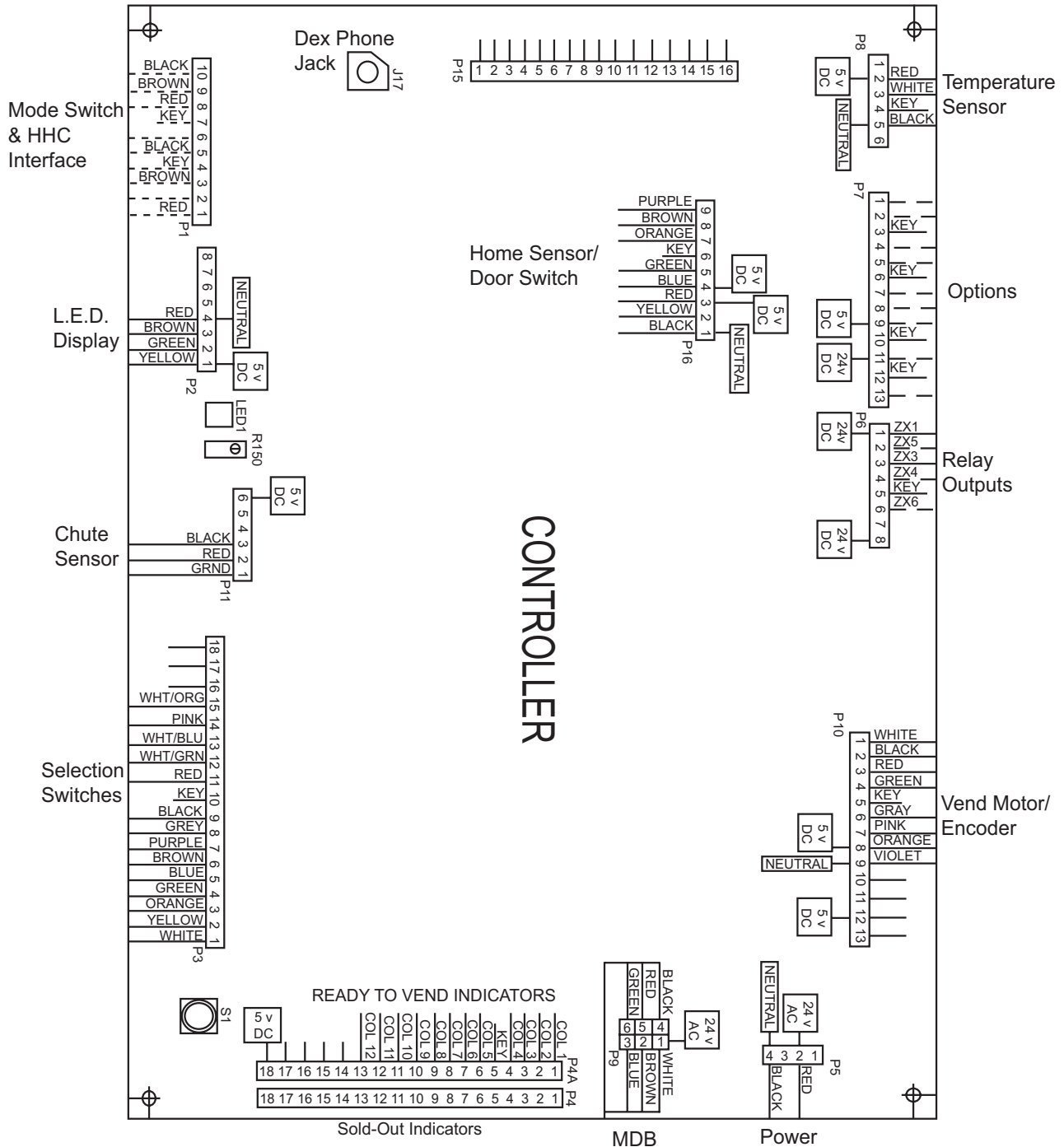

# SECTION 5: MAINTENANCE

---

## Taking Care of the Vender

### WHAT TO CLEAN

A routine cleaning schedule is the best way to ensure the best possible service and appearance from your GIII vender.

**Condenser and Evaporator Coils:** For efficient operation, the condenser and evaporator coils must be kept clear of any dirt or foreign materials. Clean dirt and lint from the condenser and evaporator coils with a brush, vacuum cleaner or compressed air.

**Drive Chain:** In the event a product leak occurs, the drive chain may become sticky and require cleaning. Remove the chain and wash it in warm, soapy water. See “Drive Chain and Actuator Assembly” section for removal procedure. In severe cases, it may also be necessary to clean the motor sprocket and idler assembly sprockets. If this is necessary, ensure that the motor and its connectors are not exposed to liquid.

**Control Board:** The vender’s control board should always be enclosed by its cover to protect it. Routine cleaning is not necessary but, if desired, the controller’s area may be blown out with compressed air.

***CAUTION:** Electrical and electronic components should never be subjected to water.*

### WHAT TO LUBRICATE

**Inner Door Gasket:** The door gasket comes from the factory pre-lubricated but should be lubricated periodically with a silicone-based grease. Apply to the vertical piece of gasket on the hinged side of the inner door which touches the vender’s main door. This will help prevent any peel-back of the gasket which can cause air leaks into the sealed cabinet, resulting in freeze-ups.

**Latch Strike Nut:** The latch strike nut should be lubricated as needed.

**The Refrigeration System:** The refrigeration system is a sealed unit and does not require any lubrication. The condenser and evaporator fan motors do not require any lubrication.

**Anti-friction Sheets:** The anti-friction sheets should be lubricated with a thin layer of food-grade silicone. The sheets should be kept clean and free of debris, and they should not be peeling.

### PREVENTIVE MAINTENANCE

**Vender Levelling:** Make sure that the vender is level when placed on site. If the vender is not properly levelled it can begin to accumulate standing water, which over a period of time may begin to freeze and will eventually freeze the evaporator. Another problem that may occur from an unlevelled vender will be improper vending, which would include but not be limited to product not vending from column, product vending slow from column, product not sliding or rolling down to the delivery port, or product jamming.

**Lighting System:** The lighting system contains high voltage. Power **MUST** be disconnected when working with or around this portion of the vender. Light bulbs should be replaced whenever one or more of the bulb ends are blackened or discoloured, or when the lights are flickering or are not lit, and it has been determined that the ballast is good. Replace these bulbs as soon as it is determined they are bad. If it is decided not to use the lighting system, the ballast **MUST** be unplugged. **DO NOT** remove the bulbs and leave the ballast plugged in. Doing so can cause the ballast to generate a very high amount of electrical noise, which can cause problems for or permanently damage electronic components.

**Product Chute:** Bottles or cans should never be placed under the product chute. Bottles can prevent air flow and may hinder the proper performance of the chute sensor.

## SECTION 5: MAINTENANCE

### Removal of Vender Components

**CAUTION:** To prevent damaging the electronics, never plug or unplug any electrical connectors with power applied.

#### Controller Board (See Figure 5.2)

Unplug the harnessing from the controller board. Remove the earthing screw or 9 mm nut from the lower right hand stand-off and free the controller board from the five nylon stand-offs by pulling out on the controller board. Some stand-offs may need to have the small tab in the centre depressed in order to free the controller board.

**NOTE:** When installing a replacement board, the chute sensor must be adjusted. See "Taking Care of the Vender" for detailed instructions.

#### Digital Display

The digital display is located on the inside of the vender outer door next to the coin chute. To remove, unplug the harness from the digital display board and pull straight out on the digital display board.

#### Low Voltage Transformer

Unplug the harness from the transformer to the fuse box. Then trace the wire from the transformer to the white connector on the harness from the EMI Filter. Remove the two 9 mm nuts securing the transformer to the outer door.

#### Coin Changer

See appropriate coin changer service manual.

#### Banknote Acceptor / Validator

See appropriate banknote acceptor service manual.

#### Card Reader

See appropriate card reader service manual.

#### Lexan Sign

First remove two 11 mm nuts on the top of the port body and four on the side of the port body (two on the left and two on the right). Then take a 9 mm socket and loosen the bolts on the right side until the sign will be ready to come off. Pull the trim to the side and pull the sign out to the left and slide the new sign in and bolt down the trim. Finally place the port trim back in and secure with bolts.

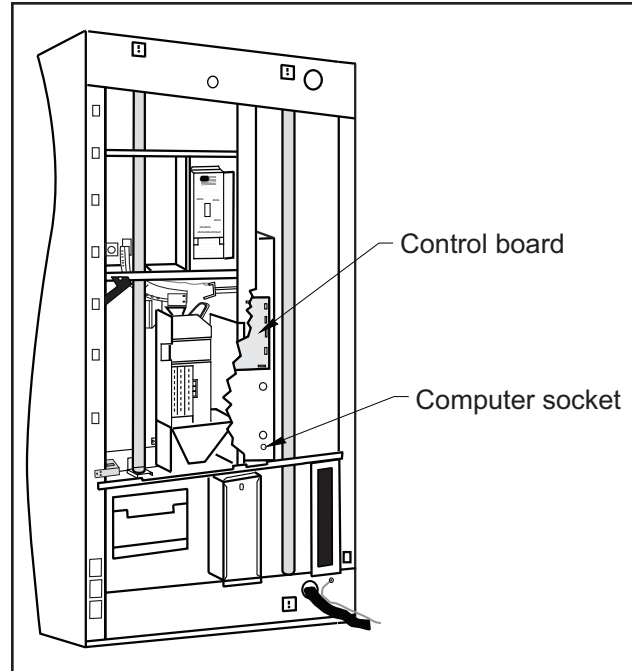

Figure 5.2

## SECTION 5: MAINTENANCE

### Delivery Chute Sensor (See Figure 5.4)

The delivery chute sensor is located on the underside of the delivery chute. To remove, lift the vinyl cover from the delivery chute. Locate the two rivets holding the delivery chute sensor to the bottom of the delivery chute. Using a 3 mm drill bit, drill out the two rivets holding the sensor to the bottom of the delivery chute. Remove the two screws from the bracket where the harness and cooling lines enter the refrigerated compartment. Trace the delivery chute sensor harness back to the controller board and unplug the harness. Remove sensor and harness assembly.

**NOTE:** When installing a replacement chute sensor, the sensor must be adjusted. See "Taking Care of the Vender" for detailed instructions.

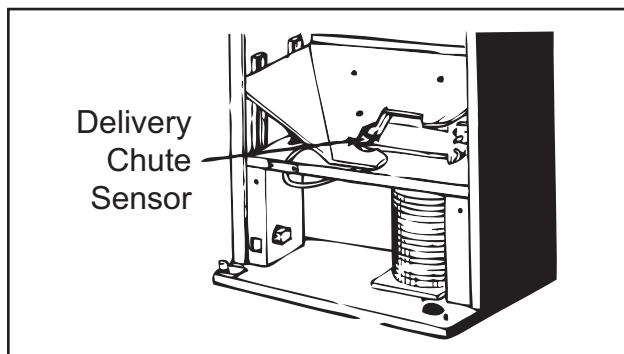

Figure 5.4

### Lights

To remove the fluorescent lights, grasp light and lift upward. Remove the bottom of light tube from fixture, lower light tube and free from the top fixture, remove light.

### Light Ballast

To remove ballast, unplug light ballast, remove the lights and remove the four screws holding the four light fixtures. Remove the one screw securing the light ballast, and remove the ballast.

### Vend Rack Assembly (See Figure 5.5)

Remove the delivery chute (see "Delivery Chute" for more details). Prop chute and its attached harness against vender door. Remove latch strike assembly by removing three 10 mm bolts. Remove vend motor from vend rack and lay in bottom of cabinet. See "Vend Motor Assembly" for more details. Remove four 10 mm hex head bolts (two at the top of rack, two at lower rear; see exploded view section 7) which secure vend rack. Slide vend rack out of vender cabinet.

**NOTE:** Place a prop under the main door to keep vender from tipping over.

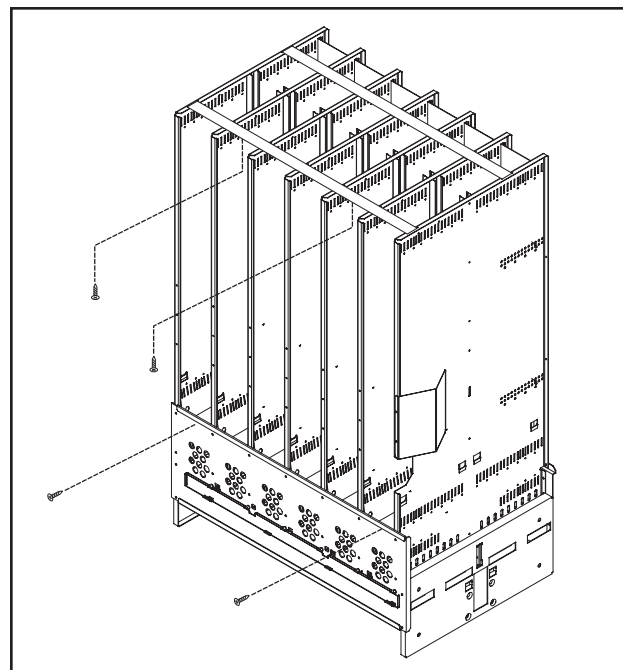

Figure 5.5

**CAUTION:** When removing the vend rack, the main door should be supported or the cabinet may fall over. The vend rack weighs 90+ kg.

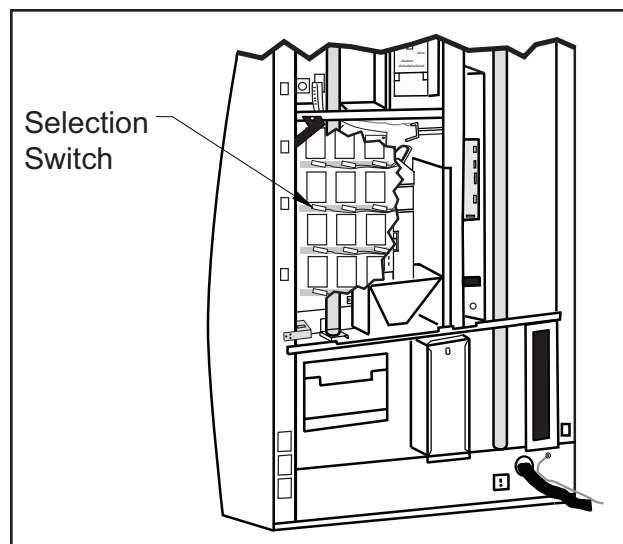

Figure 5.6

# SECTION 5: MAINTENANCE

## Drive Chain and Actuator Assembly (Figure 5.7)

The drive chain/actuator assembly is located at the bottom centre of the vend rack. To remove the drive chain and actuator (“rabbit”) assembly, remove two screws securing the spring loaded idler assembly. Use one hand to maintain tension on idler springs by pulling the two sprockets toward each other. Rotate bottom of idler assembly away from wall, then pull entire assembly downwards to free the upper two tabs from the slots. Remove chain and actuator assembly from two stabilisers and vend motor sprocket. For disassembly/reassembly of the idler assembly, see the Exploded View in Section 7.

To reinstall, loop the left hand side of chain over motor sprocket, then wrap chain around the stabilisers while

holding tension on the idler springs. Insert the idler bracket’s upper tabs into wall slots. Rotate bottom of idler assembly into position and reinstall two idler bracket screws.

**NOTE:** When reinstalling the drive chain and actuator assembly, make sure the magnets of the actuators are facing the back of the vender. Also, make sure the top run of the chain is positioned over the stabilisers.

## Chain Stabilisers (Figure 5.7)

There are two drive chain stabilisers under columns two and four that are mounted to the vender centre support. Stabilisers are fastened in place by a single screw and nut.

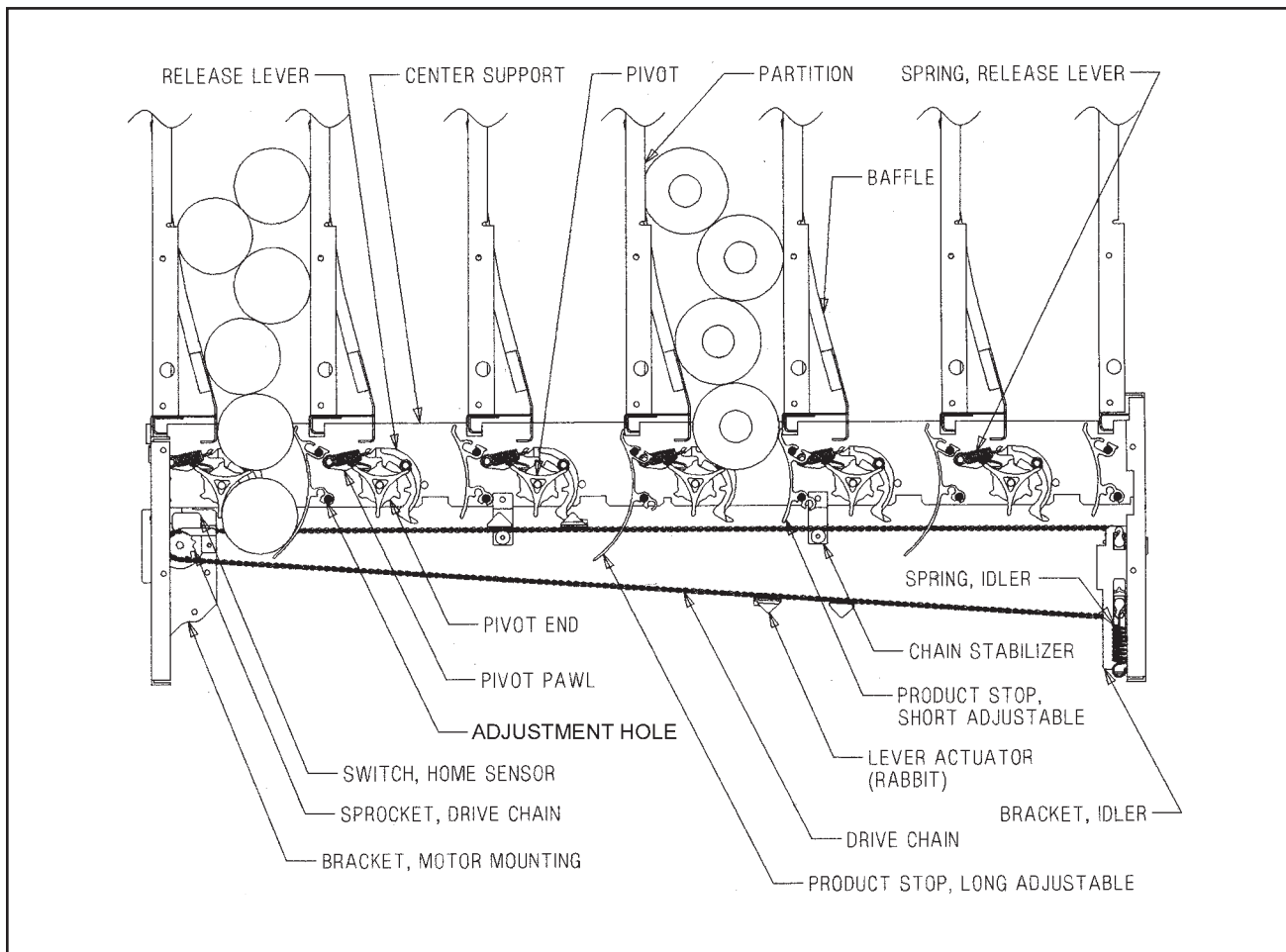

Figure 5.7

## SECTION 5: MAINTENANCE

---

### Vend Motor Assembly (Figure 5.7)

The vend motor assembly is located on the bottom left side of the vend rack assembly. To remove the vend motor, first remove the idler and chain assemblies (see “Drive Chain and Actuator Assembly” section). Remove the two screws from the vend motor bracket and rotate the lower portion of the vend motor assembly away from the left wall. The entire assembly can then be slid downwards for removal. Remove the home sensor (see “Home Sensor” section). For further disassembly, see the Exploded View of the vend motor assembly in Section 7.

***NOTE:** The motor assembly can be removed without first removing the idler and chain assemblies. This method may result in the idler assembly coming apart and may therefore require idler reassembly after the motor is reinstalled. To proceed, slip chain assembly off motor sprocket by relieving tension in the idler bracket assembly. Take care that idler assembly parts are not lost during this process.*

### Home Sensor (See Figure 5.7)

The home sensor is located on the vend motor mounting bracket just above the vend motor sprocket. To remove the home sensor, remove the two nuts which secure the home sensor, pull sensor forward and remove. Remove the two screws from the bracket where the harness and cooling lines enter the refrigerated compartment. (See Figure 5.7) Trace the home sensor harness back to the bottom of the vender outer door and unplug harness. Remove harness and sensor assembly.

### Pivot, Pivot Ends and Pivot Bearings (Figure 5.7)

***NOTE:** When removing these parts, the affected column must first be emptied of product. Rear columns **must** be emptied when removing front column parts. It is strongly advised that front columns also be emptied even when working on rear columns due to the potential danger of dumping a column of product.*

There are twelve pivot assemblies, one for each column. To remove, slide the rod retainers up. Remove the retainer to expose the head of the pivot rod. Pull the rod out slowly while holding the rear pivot. When the rear pivot is free, remove it. Hold the front pivot and pull the rod all of the way out the front of the vender to free the front pivot. Pivot ends and bearing can then be removed by pulling them straight out of the pivot.

***NOTE:** Longer pivot ends with larger “wings” go in the front columns. Toothed ends of front and rear pivot assemblies must always be to the centre of vend rack.*

### Release Lever (Figure 5.7)

***NOTE:** When removing these parts, the affected column must first be emptied of product.*

There is one release lever per column. It is located on the bottom of the vend rack on the centre support. To remove the release lever, remove the release lever spring, then remove the E-ring from the centre support pin.

### Pivot Pawl (Figure 5.7)

***NOTE:** When removing these parts, the affected column must first be emptied of product.*

These are located behind the release lever spring on the rack centre support. To remove the pivot pawl, first remove the release lever spring. This will enable the pawl to be slid off of its pivot pin.

***NOTE:** Pivot pawl will be hanging loose on pin after release lever spring is removed. The pawl must be correctly positioned on top of the pivot end before the release lever spring is reinstalled.*

### Delivery Chute (See Figure 5.8)

Remove the 4 mm hex-head bolt and Phillips head locating screw from the delivery chute (front centre of chute). Lift delivery chute slightly and pull forward. If total removal of delivery chute and delivery chute sensor is desired, remove delivery chute sensor harness as explained under “Delivery Chute Sensor” section of this manual.

### Door Switch (See Figure 5.8)

The door switch is located in the refrigerated compartment on the right side of the vender cabinet and is actuated by the vender’s inner door. To remove, unplug the door switch harness from the N/O and C terminals of the door switch. Compress the two tabs of the door switch and pull switch forward. The door switch bracket is secured by two removable screws.

# SECTION 5: MAINTENANCE

## COOLING SYSTEM

### Compressor

To remove the compressor as a sealed unit, first remove the delivery chute (see “Delivery Chute” section). Remove the two 10 mm bolts holding the compressor and condenser assembly. Remove the two screws and strap which secure the harness and cooling lines where they enter the refrigerated compartment. Remove the two screws from the sheet metal shroud to the left of the condenser coils. Remove the four screws securing the evaporator coil and pull the entire sealed system forward, being careful not to damage the drain tube.

### Evaporator Fan

With the delivery chute removed (see “Delivery Chute” section of this manual), remove the sheet metal cover from the top of the evaporator coil by pushing back and lifting on the cover. Unplug the harness coming from the fan. Remove the two 10 mm bolts from the fan (one bolt per fan). Lift fan and remove.

### Temperature Sensor (Electronic Cold Control)

The temperature sensor is located on the rear cabinet wall, behind the evaporator coil. It is secured with two screws. It will be necessary to remove the delivery chute to access the temperature sensor.

### Condenser Fan

From the back of the vender, locate the condenser fan and compressor assembly. Remove the bale strap and cover from the starter overload located on the compressor. Remove the condenser fan harness from the compressor. Remove the four screws that secure the fan assembly from the condenser. Remove fan assembly.

**NOTE:** *Condenser coils must be kept unrestricted for maximum efficiency.*

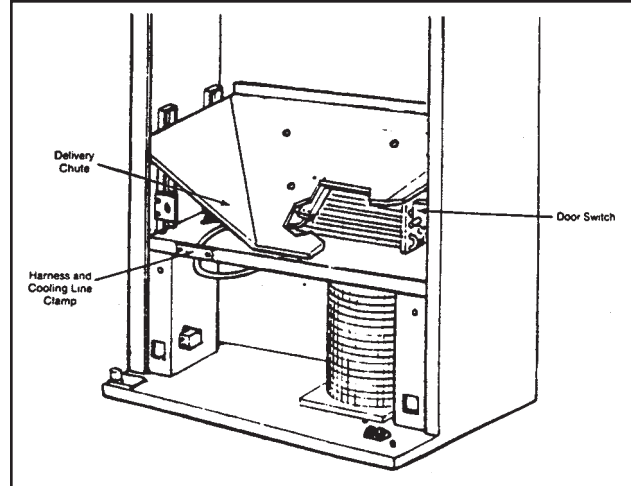

Figure 5.8



# SECTION 5: MAINTENANCE

## Troubleshooting

Refer to the Safety Segment of this manual and always remember to:

\*Remove power from vender when troubleshooting without a voltmeter;

\*Always use voltmeter when checking voltage; and

\*Beware of high voltage areas! Take extreme caution when working in these areas.

The G-III vender is equipped with a self-diagnostic feature to aid in the repair and maintenance of the vender. When servicing the vender, pay close attention to the digital display. When the vender door is opened the electronics will begin displaying any error codes that are stored in memory. If there are no errors, the display will read “nonE.” See the “Four-Button Programming” section of this manual.

To enter the Service Mode, press and release the Service Mode Button located on the controller. The display will read “Error.” If (ENTER) is pressed at the “Error” prompt, the controller will enter the error display mode. If no errors have occurred since the last error reset, the display will show “nonE.” If an error has been detected since the last error reset, the display will show the first error summary code that has occurred.

If (ENTER) is pressed, the controller will display the detailed error for the summary code. The (UP) and (DOWN) buttons will cycle through any remaining error detail codes. If (ABORT) is pressed while displaying any *detailed* code, the controller will return to the summary code. If (ABORT) is pressed while displaying any *summary* code, the controller will return to the code level.

**NOTE:** When troubleshooting errors with peripherals, the appropriate peripheral service manual(s) should also be consulted for further tests and corrective actions.

Error	Detailed Error Code	Test Procedure	Corrective Action
<b>CHAR</b> (Coin Acceptor Error) (continued on next page)	<b>EE</b> (Excessive escrow: More than 255 escrow attempts since the last coin was accepted.)	Check the escrow lever and associated mechanisms. Go to Open-door Mode and wait for 30 seconds. Manually clear the error.	If vender returns to Sales Mode from Open-door Mode without input, replace changer / acceptor. If it stays in Open-door Mode and the manually-cleared error does not reoccur, system may be okay.
	<b>nJ</b> (Coin jam)	Check changer / acceptor for jammed coins or other obstructions.	If no obstructions are apparent, replace changer / acceptor.
	<b>LA</b> (Low acceptance rate: more than 20% of the last 255 coins were rejected as slugs)	Check changer / acceptor for obstructions or dirt. Drop coins in Sales Mode or Tube Fill Mode to test acceptance.	If no obstructions are apparent and acceptance appears to be okay, this may be an indication of cheating attempts. If no obstructions are apparent and coins do not accept or acceptance rate is poor, replace changer / acceptor.
	<b>CC</b> (Changer communication error)	If card reader / banknote acceptor is being used, check for “rC” or “bC” errors. Unplug machine, wait at least five seconds, and replug.	If there is no “rC” or “bC” error: 1. Check the changer harness. 2. Replace the changer. If there is a “rC” or “bC” error, check the control board MDB harness.
	<b>tS</b> (Tube sensor error)	Check changer tubes for blockage.	Clear tube blockage, if found. If no blockage found, replace the changer.
	<b>IC</b> (Inlet chute blocked error: no coins sensed in the acceptor for over 96 errors)	Check inlet chute for blockage. Drop coins in Sales Mode or Tube Fill Mode to test acceptance. Manually clear the error.	Clear inlet chute blockage. If no blockage found, replace the changer. If acceptance rate is acceptable, system is probably okay. If acceptance rate is low or changer will not accept coins, replace the changer.
	<b>tJXX</b> (Tube jam error)	Check changer tubes and payout for blockage.	Clear blockage, if found. If no blockage found, replace the changer.
	<b>CrCH</b> (Changer ROM checksum error)	Unplug machine, wait at least five seconds, then replug machine. Manually clear the error.	If error does not clear, replace the changer.

# SECTION 5: MAINTENANCE

Error	Detailed Error Code	Test Procedure	Corrective Action
<b>CHAr</b> (Coin Acceptor Error) <i>(continued from previous page)</i>	<b>CSF</b> (Changer's scale factor is not valid for the machine configuration)	Ensure that changer, banknote acceptor, and card reader are all models for the same country. Unplug machine, wait at least five seconds, the replug machine.	If models are compatible, replace the changer.
<b>bUAL**</b> (Banknote Acceptor Error)	<b>bBC</b> (Banknote Acceptor Communication Error)	If changer or card reader is being used, check for "CC" or "rC" errors. Unplug machine and wait at least five seconds. Plug machine back in.	If there is no "CC" or "rC" error: 1. Check banknote acceptor harness. 2. Replace banknote acceptor. If there is a "CC" or "rC" error, check the control board MDB harness.
	<b>bFUL</b> (Full banknote stacker)	Ensure banknote box is empty and that the banknote box is properly closed and in place.	If banknote box appears to be okay, replace banknote acceptor.
	<b>bLL</b> (Banknote acceptor motor is defective)	No test available.	Replace banknote acceptor.
	<b>bJ</b> (Banknote jam)	Check banknote acceptor for obstructions or dirt.	If no obstructions are apparent, replace banknote acceptor.
	<b>brCH</b> (Banknote acceptor ROM checksum error)	Unplug machine, wait at least five seconds, then replug machine. Manually clear the error.	If error does not clear, replace banknote acceptor.
	<b>bOPn</b> (Open banknote box)	Check the the banknote box is closed and in the correct position.	If banknote box appears to be okay, replace the banknote acceptor.
	<b>bS</b> (Sensor error)	Check banknote acceptor for obstructions or dirt.	If no obstructions are apparent, replace the banknote acceptor.
<b>Crdr</b> (Card reader error)	<b>CrC</b> (Card reader communication error)	If changer or banknote acceptor is being used, check for "CC" or "bC" errors. Unplug machine, wait at least five seconds, then replug the machine.	If there is no "CC" or "bC" error: 1. Check the card reader harness. 2. Replace the card reader. If there is a "CC" or "bC" error, check the control board MDB harness.
	<b>CrXY*</b> (Card reader error code XY: see card reader manual for description of error codes)	No test available.	Refer to card reader manual for corrective action.
<b>OLn</b> (Online module)	<b>OC</b> (Online module communication: no communication for five seconds)		Proper communications.
	<b>OnC</b> (Online network communication: network is not responding; OLM cannot call out)		Proper communications.
	<b>OI</b> (Online module internal problem, causing improper functions)		
<b>rUnd</b> (Remote vend)	<b>rUC</b> (Remote vend mechanism: no communication for five seconds)		Proper communications.
<b>S-d</b> (Selection / display device)	<b>SdC</b> (Display device communication: no communication for five seconds)		Proper communications.
	<b>SdXX</b> (Error code number XX: see device spec for description of error codes)		

\* Error code must be manually cleared. See "Error" section of this manual for detailed instructions.

\*\* These error codes will be automatically cleared when the banknote acceptor reports no errors and is enabled (the acceptor is "enabled" when it accepts money).

## SECTION 5: MAINTENANCE

Error	Detailed Error Code	Test Procedure	Corrective Action
rFrG (Refrigeration error)	SEnS (Unplugged or defective temperature sensor error)	Check the temperature sensor connection at the control board to make sure the sensor is plugged in. Check to see that it is wired properly and the pins are making contact.	If the sensor is unplugged, replug it. If it is miswired, replace the temperature sensor. If the connections are bad, attempt to repair them or replace the temperature sensor if it is unrepairable.
	CoLd (Temperature 3°F / 1.5°C or more below the compressor cut-out setting)	<ol style="list-style-type: none"> <li>1. Check the refrigeration unit before opening the vender's main door to see if it is running.</li> <li>2. Open the vender's main door and see if the unit cuts off.</li> <li>3. Make sure the vender's door switch is working properly.</li> <li>4. Unplug one of the two white wires plugged into the refrigeration relay.</li> </ol>	<p>If upon unplugging one of the white wires, the unit stops:</p> <ol style="list-style-type: none"> <li>1. Check the temperature sensor reading.</li> <li>2. Check SetP settings.</li> <li>3. Check the two white wires for shorts from the control board.</li> </ol> <p>If upon unplugging one of the two white wires, the unit still runs:</p> <ol style="list-style-type: none"> <li>1. Unplug one of the black wires. If the unit stops, replace the refrigeration relay. If optional heater kit is not installed, one may be required.</li> <li>2. If heater kit is installed and heater does not turn on (heater relay does not click upon energising with the relay test mode), check the two white wires from the board to the heater relay for voltage. (There should be 24 VDC on one of the two wires.) Check the other wire for continuity between the control board and the relay. If voltage is okay, replace the relay. Otherwise, replace the control board.</li> </ol>
	Hot (Cabinet temperature is above the limit)	Proceed with normal refrigeration troubleshooting. Refer to the refrigeration troubleshooting flowchart.	
	Htr (Heating system has failed to increase 1°F / 0.5°C per hour)	Proceed with normal refrigeration troubleshooting. Refer to the refrigeration troubleshooting flowchart.	
	CnPr (Compressor is not cooling within 30 minutes of turning on)	Check the refrigeration unit before opening the vender's main door to see if it is running.	If the unit is running, clear the error to see if it reoccurs.
		Open the vender's main door and check the display to see that the door switch is working as normal.	If the display does not function as normal, check the door switch circuit.
		Access the "rFrG" mode and check the "SetP" settings. While in "rFrG," change "dSP" to "1" to show the temperature on the display during the greeting and see if it is correct.	Change any settings, if necessary, and check the temperature sensor operation.
		While in the "tEST" mode, access the "rELY" mode and turn the compressor on.	If the unit does not run (refrigeration relay not clicking upon energising with the relay test mode), check the two white wires from the board to the refrigeration relay for voltage. There should be 24 VDC on one of the two wires). Check the other wire for continuity between the control board and relay. <b>Note:</b> The compressor relay test mode must be on to check voltage.

\* Error code must be manually cleared. See "Error" section of this manual for detailed instructions.

# SECTION 5: MAINTENANCE

Error	Detailed Error Code	Test Procedure	Corrective Action
<b>SEL</b> (Selection switch error)	<b>SSXX</b> (Selection switch has been closed for more than 25 seconds, where "XX" indicates the selection switch number)	Check the selection switch number shown in the detailed error code "XX" to see if: 1. The button is sticking; 2. The switch is sticking / defective; 3. The harness is wired wrong / shorted.	Try to correct the problem if one of the three is found. If it cannot be corrected, replace the component in question.
<b>StS</b> (Space-to-sales error)	<b>UAXX</b> (Unassigned column, where "XX" indicates the column number)	Access the Space-to-sales Mode ("StoS") and go to Custom Space-to-sales ("CStS"). Check all selections for the column shown in the detailed error code "XX."	Change the space-to-sales settings as required. In some situations, it may be quicker to completely reset all space-to-sales settings.
<b>UEnd</b> (Vend mechanism error)	<b>hS*</b> (Home sensor error)	Observe the chain to make sure the four actuators ("rabbits") are attached. Make sure two of the four actuators have magnets pressed in them.	If defective, replace the chain assembly.
		Make sure that the magnets are facing the rear of the cabinet.	If the magnets face forward, the chain is installed backward. Remove the chain and reinstall it so that the magnets face the rear of the cabinet.
		Check the location of the chain. The actuators should be at each end of the cabinet. Pull the chain until both sets of actuators are in the middle of the cabinet. Power the vender down, then restore power. The bottom set of actuators should end up in the home position.	If the motor jerks but does not rotate the chain, check the motor's wiring to the control board. If nothing is found, replace the vend motor assembly. If the chain rotates several times without an actuator stopping above the vend motor (at the home sensor), check the above test. If it is okay, then check the home sensor wiring to see if it's pinched or shorted. Replace the home sensor if nothing is found.
	<b>EC*</b> (Encoder error)	Learn how column sequencing works and vend from all columns, watching the actuators locate each column.	If the encoder is defective, the vend motor will not be able to find the release levers for one or more of the columns and will stop at a place where there is no release lever. Replace the vend motor assembly. This error may also indicate that the chain is sticky, making it difficult for the chain to move. See "Taking Care of the Vender" on how to clean the chain.
	<b>rE*</b> (Rabbit error)	Closely examine the four rabbits (actuators) mounted on the chain assembly. Make sure they are tightly mounted and none are missing.	If an actuator is missing, replace the chain assembly.
		Check to make sure that the upper run of the chain assembly is above the stabilisers.	If the upper run of the chain assembly is below the stabilisers, raise it above them.
Check the chain's alignment under the mechanism. Check the idler pulley sprocket and the vend motor sprocket to see if aligned.		If the idler pulley sprocket is in the wrong position on the shaft, order a new idler sprocket assembly. If the vend motor sprocket is in the wrong position on the shaft, order a new vend motor assembly.	
<b>Chut</b> (Chute sensor error)	<b>CS*</b> (Chute sensor error: chute sensor is active for more than five minutes)	Check to make sure the sensor is properly adjusted. Make sure the adjustment only blinks on when product impacts the delivery chute.	Adjust the sensor to factory spec. See "Taking Care of the Vender" in Section 5 for detailed instructions.

\* Error code must be manually cleared. See "Error" section of this manual for detailed instructions.

## SECTION 5: MAINTENANCE

Error	Detailed Error Code	Test Procedure	Corrective Action
COLJ (Column jam error)	CJXX* (Column jam error, where "XX" indicates the column number)	Check column for problem.	Correct problem.
		Check for contamination on release lever, pivot, and pivot end.	Clean contamination.
		Enter "tESt" and vend one time from column.	If two or more products are received, increase chute sensor sensitivity or replace chute sensor. To increase sensitivity, turn screw clockwise. See "Chut" section.
Ctrl (Control system error)	dS* (Door switch error)	Check the vender's door to see if it's sticking or miswired. If nothing is found at the door switch, check two wires from door switch to control board to see if they're pinched or shorted.	Replace the door switch, if defective. Repair or replace the door switch harness to the control board.
	ACLo* (Average rectified voltage was under 22 VDC for at least 30 consecutive seconds)	Check for low voltage at the wall outlet, at refrigeration unit startup with all else on circuit running, in an "extreme" condition.	If low voltage cannot be found on the wall outlet in an extreme condition, check for shorts in the vender.
	rAM (Setup info corrupted)	No test available.	If error shows up frequently, replace the control board.
	SF (Scale factor error)	Check the connections of the changer harness. Make sure the changer is plugged in and is working.	Make corrections to the harness or replace the changer if necessary.
	IS (Inlet sensor blocked)		Check the changer harnessing for cut, pinched, or crimped wires. Replace the changer.
	Ib (Inlet blocked)		Check the inlet for blockage. If nothing is found, check the changer harnessing for cut, pinched, or crimped wires. Replace the changer if necessary.

Error / Problem	Possible Cause / Test Procedure	Corrective Action
<b>COIN ACCEPTANCE / PAYOUT (RECORD ALL ERRORS ON PAPER)</b>		
Coin mechanism will not accept coins.	No power to board.	Check to make sure the LED and the sign lighting are lit. Check fuse and transformer.
	Harness from coin mech to board is cut or disconnected.	Using a voltmeter, check each wire for continuity and to earth.
	Short in coin mechanism.	Unplug all connections from the control board except the transformer and coin mech connections. Test acceptance. If it accepts, replug each connection one at a time and test acceptance after each.
	Acceptor is dirty or other problem may exist (not tuned).	Clean acceptor or contact your local coin mech distributor.
	Short in control board.	If above procedures do not work, replace control board.
No acceptance or rejects a percentage of good coins. <i>(continued on next page)</i>	Coin return lever pressing down on acceptor's coin plunger.	Make sure changer is mounted correctly and the coin return lever is in the proper position.
	Acceptor is dirty or foreign matter is in the path.	Clean acceptor or contact distributor.

\* Error code must be manually cleared. See "Error" section of this manual for detailed instructions.

# SECTION 5: MAINTENANCE

Error / Problem	Possible Cause / Test Procedure	Corrective Action
No acceptance or rejects a percentage of good coins. <i>(continued from previous page)</i>	Coin changer is improperly tuned (if tunable).	Contact manufacturer for tuning.
	Defective control board.	Replace / test control board.
Always accepts coins but gives erratic / no credit.	IF NO CREDIT: Defective harness between coin mech and control board (will have "CC" error).	Check harness for cut wires or wrong / bad connections. Test each wire for continuity or test to earth. If found to be defective, replace the harness.
	IF ERRATIC OR NO CREDIT: Acceptor or coin mech.	Replace coin mech and test.
	IF NO CREDIT: Defective control board.	Replace control board.
Changer will not pay out coins.	Defective harness from coin mech to control board.	Test vender's manual coin payout. If vender won't pay out using the CPO mode or during sales, check harness for cuts, bad continuity, or wrong connections. If defective, replace and test.
	Defective coin mech.	Replace coin mech and test. If it pays out, the coin mech was defective.
	Defective control board.	If coin mech won't pay out coins manually in the CPO mode or during the Sales Mode and the above procedures have failed, replace the control board and test payout both in the CPO mode and during a sale.
	Change payout buttons are disabled while door is closed or while in Open-door Mode.	Enter the Service Mode or access the Coin Payout Mode ("CPO").
<b>BANKNOTE ACCEPTANCE</b>		
Banknote acceptor won't pull banknote in.	No power to note acceptor.	Unplug vender for 10 seconds and replug to see if banknote acceptor cycles. If not, check acceptor harnessing or replace the note acceptor.
	Wrong acceptor harness or wires of the harness are in the wrong position.	Make sure that the acceptor harnessing is correct for your style of acceptor and that it is wired properly.
	Acceptance disabled by coin mechanism (if present), or bad harnessing.	Make sure that the coin mechanism is plugged in (accepts coins) and that the coin tubes have enough coins to enable banknote acceptance.
	Coin mech is not operative.	Make sure that the changer harnessing is correctly connected and has continuity. Repair or replace if necessary.
	Replace acceptor and test. If acceptor pulls banknote in, acceptor was defective.	Replace banknote acceptor.
Banknote acceptor takes a banknote but will not establish a credit.	Defective acceptor harness (credit not getting from acceptor to control board through the harness).	Make sure that the acceptor harnessing is correct for your style of acceptor and it is plugged in / wired properly.
	Defective acceptor.	Replace / test acceptor.
	Defective control board.	Replace / test control board.
Banknote acceptor takes a banknote and establishes credit, but credit will not erase.	Defective / wrong acceptor interface harness.	Refer to banknote acceptor service manual or banknote acceptor representative.
	Defective banknote acceptor.	Replace acceptor, and test acceptance and erasure of credit.
	Defective control board.	Replace / test control board for erasure of credit.
Acceptor takes a banknote and allows payback of coins without a selection.	Controller configurations not set properly.	Access vender configurations mode and check the Forced Vend Attempt setting.

# SECTION 5: MAINTENANCE

Error / Problem	Possible Cause / Test Procedure	Corrective Action
<b>VENDING PROBLEMS</b>		
Multiple vending (not cancelling credit)	If multiple vending is from all selections, delivery sensor is cut or improperly earthed. <b>NOTE: If the sensor is not present or is cut (defective), the GIII will allow up to two products from each column assigned to be vended before the column is determined to be sold out.</b>	Factory adjustment for the trim pot screw on the controller: 1. Turn screw clockwise until the light comes on. 2. Turn screw anti-clockwise until the light goes out. 3. Continue turning anti-clockwise 2 full turns. 4. Vend test on columns 7 and 12, and watch the light on the board. Make sure the only time the light comes on is when a product hits the can chute.
	Depth setting not set correctly in "SdEP" mode (may be set to single depth).	Enter "SdEP" mode and check the setting to make sure it is correct. Refer to "SdEP" section of this manual. <b>NOTE: "SdEP" is <i>always</i> set by selection number.</b>
	Mechanical error.	Check for correct operation of the pivot, pivot end, and release lever. Verify that both adjustable product stops are set to the correct position for the package type.
Wrong product vending upon selection.	Misload by vender loader.	Ensure that all product within each column is the same.
	Space-to-sales not set properly.	Look for StS error. Check or reset space-to-sales.
	Miswired selection.	Check the wiring from the control board to the selection switches.
	Bad encoder (motor assembly). (" <i>UEnd</i> " error should be displayed.)	Watch vend cycle from under stack mechanism. Know the columns you're vending from (preferably one column assigned to the selection). If the lever actuators (rabbits) do not come close to this column upon vending, change the motor assembly.
No vend upon selection. Dry vend (no refund).	Chute sensor too sensitive, or a column is jammed or sold out.	Check to see if the delivery chute sensor adjustment LED is constantly on. If so, adjust it back to factory setting. See "Taking Care of the Vender" in Section 5. Check adjustable product stops to ensure that both are set to the correct position.
	Defective chute sensor.	Unplug the sensor's connection from the control board. Watch the LED. If the adjustment LED goes out, replace the defective sensor.
	Defective control board.	If the adjustment LED stays on after unplugging the sensor from the control board, power it down (pull the fuse), and unplug everything from the control board except the main power lead. Reinsert the fuse. If the adjustment LED lights up straight away, turn the screw anti-clockwise to see if the light goes out. If not, replace the control board.
Will vend from some but not all columns (allows refund or second choice). (continued on next page)	Select button, switch, or harnessing.	Check the selection switch. Trace the selection harness back to the control board. Replace if necessary.

## SECTION 5: MAINTENANCE

Error / Problem	Possible Cause / Test Procedure	Corrective Action
Will vend from some but not all columns (allows refund or second choice). (continued from previous page)	Defective encoder. ( <i>"UEnd" error should be displayed.</i> )	Watch vend cycle from under stack mechanism. Know the columns you're vending from (preferably one column assigned to the selection). If the lever actuators (rabbits) do not come close to this column upon vending, check the motor connections at the control board and in the bottom of the door. If the connections look good, replace the vend motor assembly.
Complete sold-out condition, motor rotates chain several times, then the display shows "Sold Out" or "Out of Order."	Home sensor, chain, or lever actuators (rabbits).	Pull chain out into the middle of the column and unplug power to door, then replug. If the motor rotates the chain several times without finding the home position, check / change the home sensor and chain.
Complete sold-out condition.	Timer is enabled or "StS" has been cleared.	Disable timer control. Check space-to-sales settings; reprogram if necessary.
	Door switch not working.	Open the vender's main door, and make sure the LED displays the Service Mode. If not, check for voltage (5 VDC) with a voltmeter at the door switch. If voltage is found, replace the door switch. If not, check for voltage (5 VDC) at the door switch's pinout on the control board. If no voltage is found there, replace the control board.
<b>MISCELLANEOUS PROBLEMS</b>		
Display shows "Sold Out" immediately upon pressing selection button of a full column (sold-out condition not clearing).	Door switch wiring incorrectly connected or cut / pinched.	Check for cuts on the two door switch wires going from the switch to the control board. Also, check for bad connections.
	Door switch.	Check the door switch to see if it is defective. Use a voltmeter to measure for voltage between the COM / NO positions and COM / NC positions.
	Control board.	Check the control board by checking voltage across the two pins for the door switch at position P16 on the board. If no voltage is found, replace the control board.
Vender appears dead; no digital display and no lights.	Defective main harness. Secondary power harness to the transformer. Lights defective.	Replace main wiring harness. Replace secondary power harness. (See interconnect drawing.)
No digital display; vender lights are on.	Transformer not properly connected or defective.	Check transformer connection. Check power with voltmeter from transformer to control board. (See interconnect drawing.) Replace if necessary.
	Defective display or display harness.	Check display and display harness. Replace if necessary.
	Defective control board.	Replace control board.
Vender scrolls message on display but does not accept money.	Changer out of tune.	Refer to changer manual or contact distributor.
	Defective changer.	Replace changer.
	Defective control board.	Replace control board.
Vender accepts money but does not establish credit.	Defective changer.	Replace changer.
	Defective control board.	Replace control board.
Vender accepts and credits money but does not vend (does not indicate a sold-out condition).	Defective selection switch.	Check selection switch. Replace if necessary.
	Defective selection switch harness.	Check harness. Replace if necessary.
	Defective control board.	Replace control board.



## SECTION 5: MAINTENANCE

Error / Problem	Possible Cause / Test Procedure	Corrective Action
Vender delivers wrong product.	Vender loaded incorrectly.	Correct loading.
	Defective encoder.	Replace vend motor assembly.
	Defective control board.	Replace control board.
Flashing 8's across the LED.	Chips on control board not seated properly (GII VII and EVS control boards).	Seat the chips down properly.
	Bad LED connection.	Scrape the pins on the LED and reinstall harness.
	Defective control board.	Unplug everything from the control board except the LED and main power. If the 8's remain, replace the control board.
	Defective components.	If the 8's have disappeared from the previous step, begin plugging in harnesses one at a time. Replace whatever causes the 8's to reappear.
Solid 8's across the LED.	Defective LED.	Replace LED and / or harness.
	Defective control board.	Replace control board.
"Out of Order" on the LED.	Defective home sensor, chain assembly, or control board.	Make sure the lead actuator ("rabbit") is at the top of the vend motor (in the home position). Make sure the magnet on the lead actuators face toward the rear of the cabinet. Check voltage with a voltmeter at the control board, position P16. Check for 5 VDC across pins 1 and 3. The two wires will be red and black. If voltage is found, check for the same voltage at the bottom of the door. This will be a three way connector. Replace whatever it is that you do not find voltage at. If the correct voltage is found everywhere, replace the home sensor.
<b>ELECTRONIC REFRIGERATION</b>		
Refrigeration unit will not run. The cabinet temperature reads 255°F / 124°C or 17°F / -8.5°C.	Defective temperature sensor.	1. Check connection. 2. Replace temperature sensor.
Vender will not display a temperature when "dSP" is set to "1."	Unplugged temperature sensor.	Make sure temperature sensor is securely plugged in at control board.
	Defective temperature sensor.	Unplug the existing sensor, and plug the new sensor up. Earth the new sensor to the board. Hold down the door switch, and see if the LED displays a temperature.
	Defective control board.	If it does not display a temperature, replace the control board.
Refrigeration unit will not run.	Defective unit.	Plug the unit directly to the wall outlet to see if it runs and cools. If not, then replace the unit. <b>(DANGER: ELECTRIC SHOCK HAZARD. When plugging in the refrigeration unit directly to a wall outlet or other power source, always ensure that the vender itself is also plugged in to an earthed electrical outlet. Failure to do so could cause an electrical shock, possibly resulting in severe injury or even death.)</b>
Unit will only run in the compressor relay test mode. <i>(continued on next page)</i>	Defective door switch.	Open and close the door to make sure the LED scrolls. If not, then check the door switch, harness, or control board.

# SECTION 5: MAINTENANCE

Error / Problem	Possible Cause / Test Procedure	Corrective Action
Unit will only run in the compressor relay test mode. <i>(continued from previous page)</i>	Defective temperature sensor.	Set "dSP" to "1" in Refrigeration Mode. If the temperature shown is inaccurate, replace the temperature sensor.
	Wait for the delay after the door is closed (5 to 10 minutes).	Wait to see if the unit comes on. If not, replace the control board.
Unit will not run in the compressor relay test mode. <b>NOTE:</b> Leave the compressor relay test mode on in order to check for voltage with the voltmeter.	Defective control board.	Check for 24 VDC with a voltmeter across pins 1 and 3 of the control board. If no voltage or incorrect voltage is found, replace the control board.
	Defective adapter harness (GII VII and EVS boards).	Check wires 1 and 3 for the same voltage as above with a voltmeter. Replace if incorrect.
	Defective regulator board (GII VII and EVS boards).	Check for 24 VDC with a voltmeter across pins 1 and 3 at the top of the regulator board. Replace if incorrect.
	Defective relay harness.	Check for 24 VDC with a voltmeter at the relay across the two wires with pink connectors. Replace if incorrect.
	Defective relay.	Check for 230 VAC on the contact side of the relay with a voltmeter. Replace if incorrect.
Refrigeration unit runs constantly.	Defective door switch.	Upon opening the door, the LED should not show "Ice Cold...". If it does, check the door switch wiring. Replace the door switch if necessary.
	Defective control board.	Replace the control board.
	Adapter harness wired incorrectly (GII VII and EVS boards).	Check to make sure the harness wires are in order, from ZX1 to ZX6. Correct the wires if wrong.
	Defective relay. Contacts are welded together.	Unplug one of the wires with the pink connectors from the relay. Also unplug the 230 VAC side of the relay. If the unit cuts off, replace the relay.
	Defective main power cord.	If the unit continues to run after unplugging everything from the relay, replace the main wiring harness (junction block).
Evaporator freeze-up.	Check the steps above if the unit runs when the door is open.	See above.
	Evaporator fan not running.	Check the wiring to the evaporator fan. Check for 230 VAC with a voltmeter. If no voltage is found, replace the junction block. If the correct voltage is found, replace the evaporator fan motor.
	Air leaks around the inner door or port body.	Check for condensation around the inner door for air leaks. Ensure the door is tightened down far enough. Make sure the port door is not held open.
	Mullion area not properly sealed (area where the harnesses enter the cabinet).	Apply permagum.
	Drain tube clogged.	Check to make sure water can freely flow through the drain tube.
	"SetP" set too low.	Increase "SetP" to 40°F / 4.5°C.
	Refrigeration unit low on coolant.	Replace refrigeration unit.

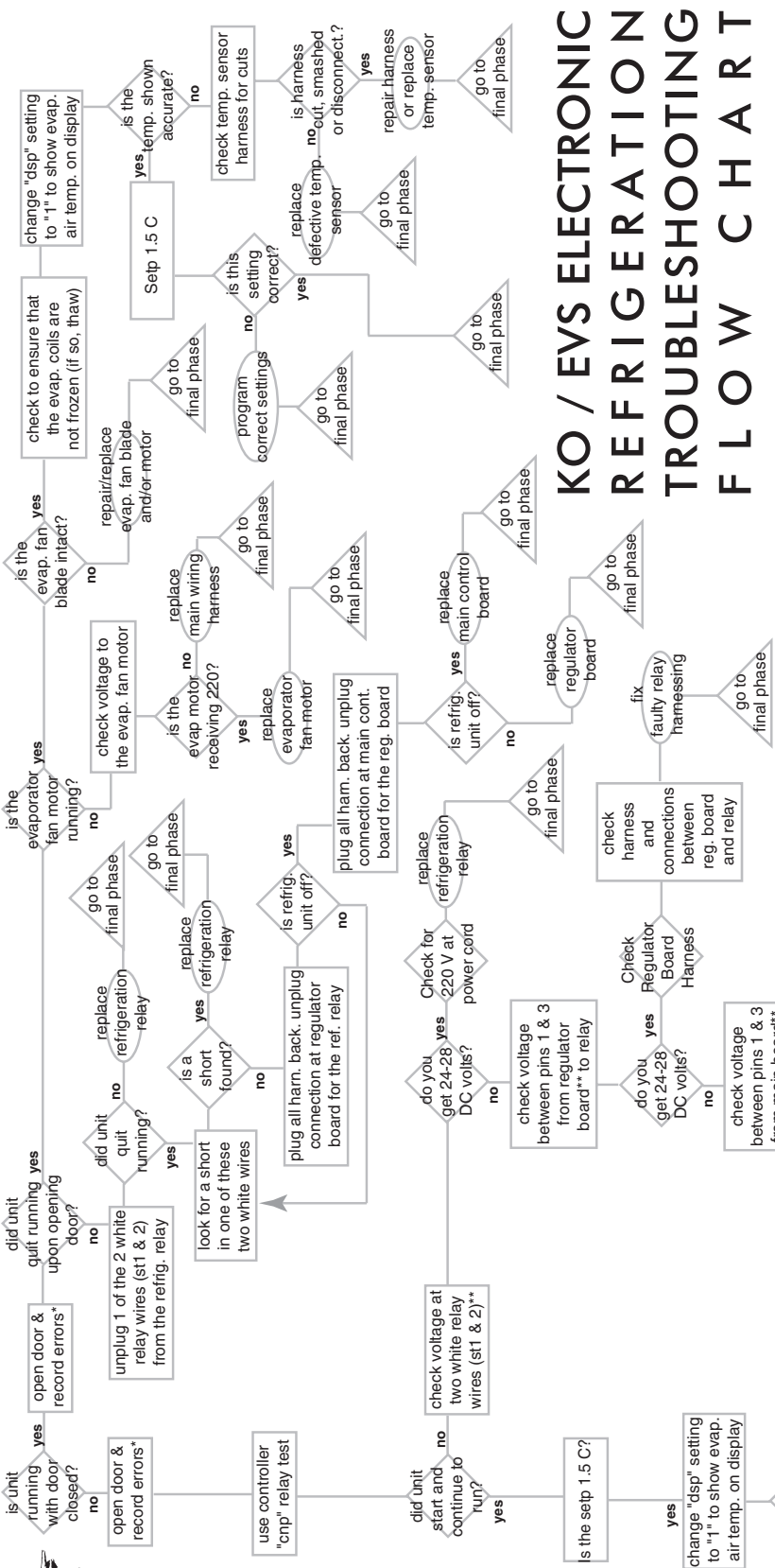

## KO / EVS ELECTRONIC REFRIGERATION TROUBLESHOOTING FLOW CHART

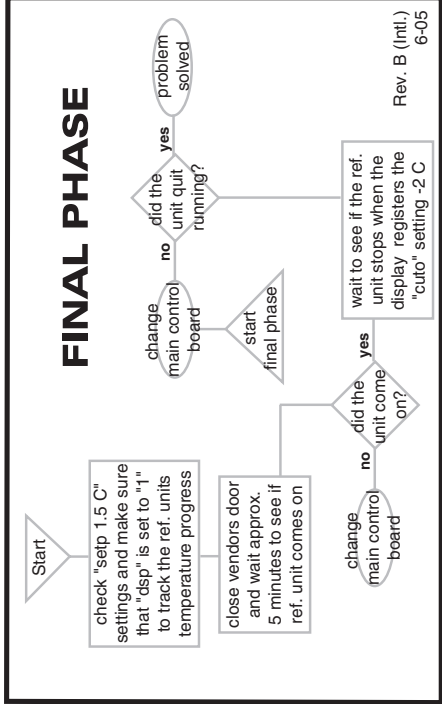

\*normal errors are "cnp" and "cold" for this type of problem.  
 \*\*for voltage to be read, you must first enable the compressor (via the "rely" mode).  
 \*\*\*for this type of problem it is recommended that the settings be setp 1.5 C.

# SECTION 6: OPTIONAL EQUIPMENT

---

## G-III Options

### **Kits For Vending Additional Packages**

For the latest information on kits that will enable the G-III to vend packages not listed on the inner door label, please contact Royal Vendors' Customer Service Department.

### **Hand Held Computer (HHC)**

The G-III Vender interfaces with the Direct Exchange/Uniform Communications Standard (DEX/UCS) and DEX/UCS Compatible Hand-held Computers (HHC). The HHC may be used to program the G-III Vender's vend price and (STS), as well as other pertinent MIS and security information. The HHC interfaces to the vender's controller board via the computer socket located near the top of the main door. Once the HHC is connected and meets initial communication requirements, it may then be used to program the G-III Vender. For more information on the HHC, see separate HHC manual.

### **External MIS Plug**

An external MIS Plug is available with Kit #842099.

*Install in accordance with kit instructions.*

### **Light Kit**

Kit #141160

### **Heater Kit**

Kit #141153

### **Override Key Switch Kit**

Kit #231107

# exploded views

# SECTION 7: EXPLODED VIEWS

## KO Control Board and Wiring

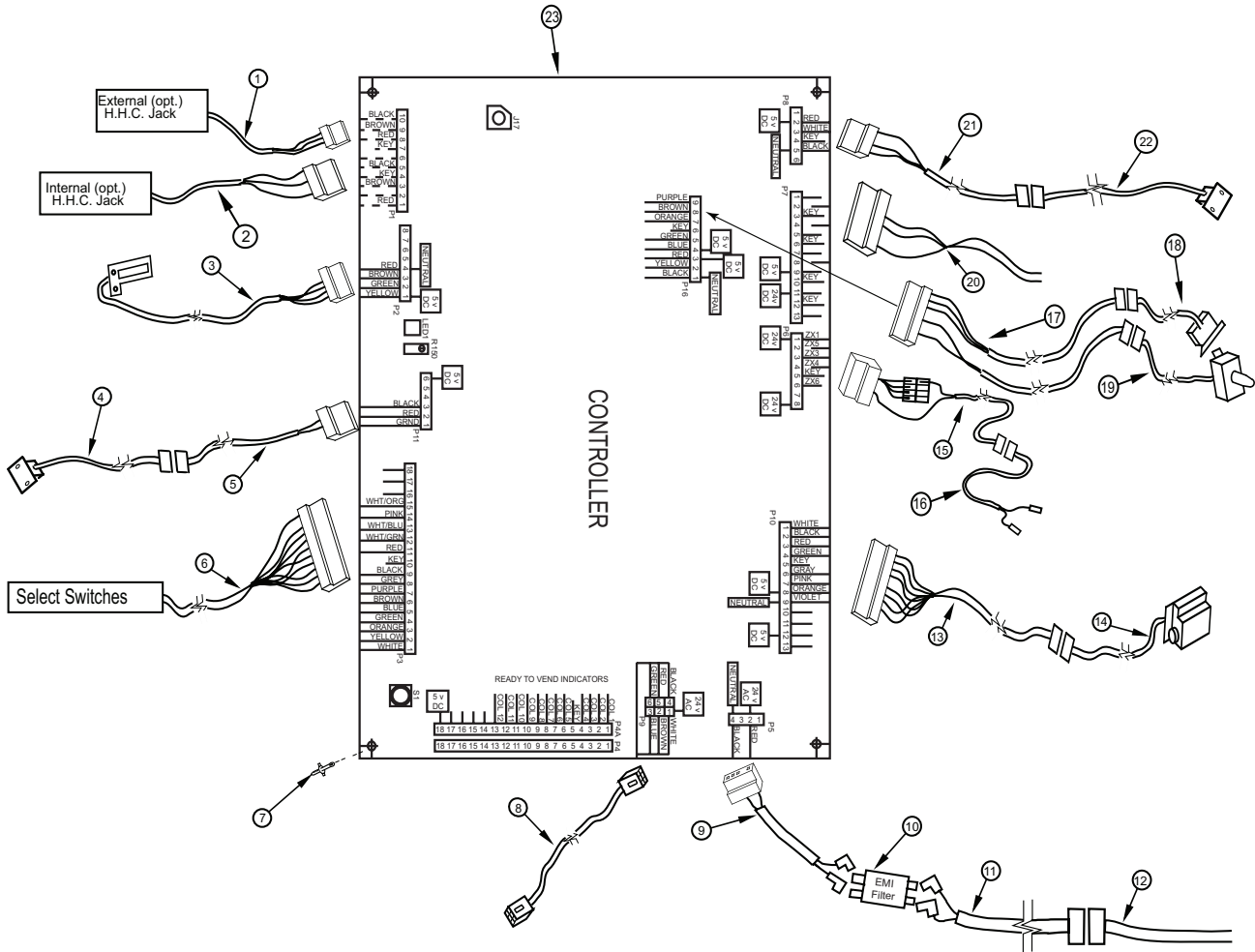

Item No.	Description	Part Number	Qty.
1	External DEX Harness (Opt)	842095	1
2	Internal DEX Harness (Opt)	842148	1
3	LED Harness	842081	1
4	Chute Sensor, Door Side	836122	1
5	Chute Sensor, Cabinet Side	210122	1
6	Selection Switch Harness		
	-13 Select	842216	1
	-12 Select	842472	1
	-9 Select, Landscape	842044	1
	-9 Select, Marketing	842217	1
	-8 Select	842473	1
7	Stand Off	916066	5
8	Serial Changer Extension Harness, CCR	842244	1
	- Landscape	842261	1
9	Harness, Filter to Board	842196	1
10	EMI Filter	842061	1
11	Harness, Trans. to Filter, Door Side	842253	1
12	Harens, Trans. to Filter, Cabinet Side	842254	1

Item No.	Description	Part Number	Qty.
13	Vend Motor Harness	842083	1
14	Motor Assembly	210727	1
15	Refrigeration Relay Harness, Door Side, Landscape - Marketing	842236 842235	1 1
16	Refrigeration Relay Harness (Cabinet Side)	842237	1
17	Door Switch / Home Sensor Harness	842080	1
18	Home Sensor Harness (Cab)	842052	1
19	Door Switch Harness (Prior to 1521)	842047	1
	(1521 & After)	842228	1
	(1521 & After) Marketing	842229	1
20	Options	Call RV Cust. Srvc.	
21	Temp. Sensor, Door Side	822047	1
22	Temp. Sensor, Cabinet Side	822046	1
23	KO Control Board	836254	1
•	KO Board Cover	815468	1
•	EMS Motion Sensor	842729	1

# SECTION 7: EXPLODED VIEWS

## EVS Control Board and Wiring

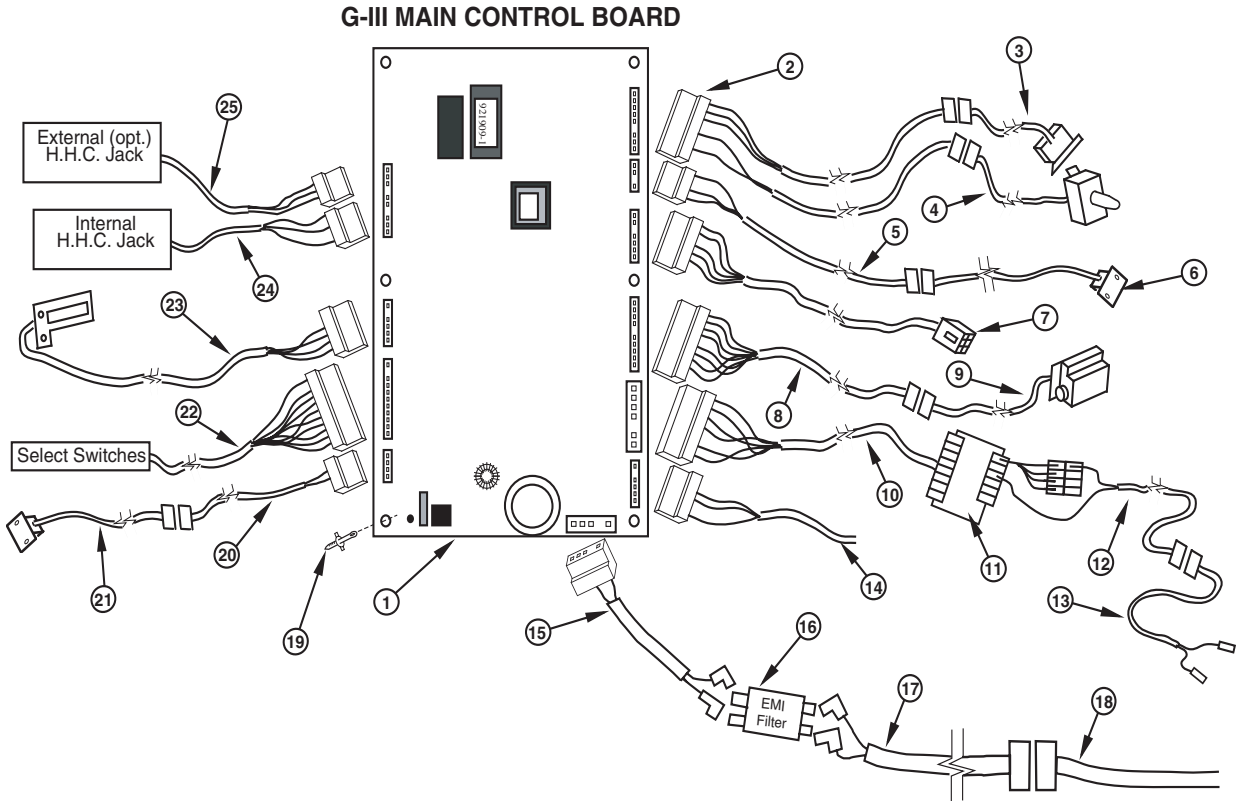

Item No.	Description	Part Number	Qty.
1	Control Board	836115	1
2	Harness, Home Sensor/Door Switch	842080	1
3	Homes Sensor Assembly	842052	1
4	Door Switch Harness		
	- Before 1521	842047	1
	- 1521 & after	842228	1
	- 1521 & after - Marketing	842229	1
5	Temp. Sensor, Door Side	822047	1
6	Temp. Sensor, Cabinet Side	822046	1
7	Harness, Serial	842079	1
8	Harness, Vend Motor	842083	1
9	Vend Motor Assembly	210727	1
10	Harness, Regulator Board	210502	1
11	Refrig. Regulator Board	836081	1
12	Harness, Refrigeration, Relay Door Side	141904	1
13	Harness, Refrigeration Relay, Cabinet Side	141905	1

Item No.	Description	Part Number	Qty.
14	Options	Contact RV Cust. Service	
15	Harness, Filter to Board	842196	1
16	EMI Filter	842061	1
17	Harness, Trans. to Filter, Door Side	842253	1
18	Harness, Trans. to Filter, Cabinet Side	842254	1
19	Board Stand-off	916066	5
20	Chute Sensor, Door Side	836122	1
21	Chute Sensor, Cabinet Side	836121	1
22	Harness, Sel. Switch, 13 select	842216	1
	-9 select	842044	1
23	LED Harness	842081	1
24	Jack, Internal HHC	842110	1
25	MIS External DEX Harness	842095	1
•	MDB Harness	842116	1

# SECTION 7: EXPLODED VIEWS

## Cabinet Assembly

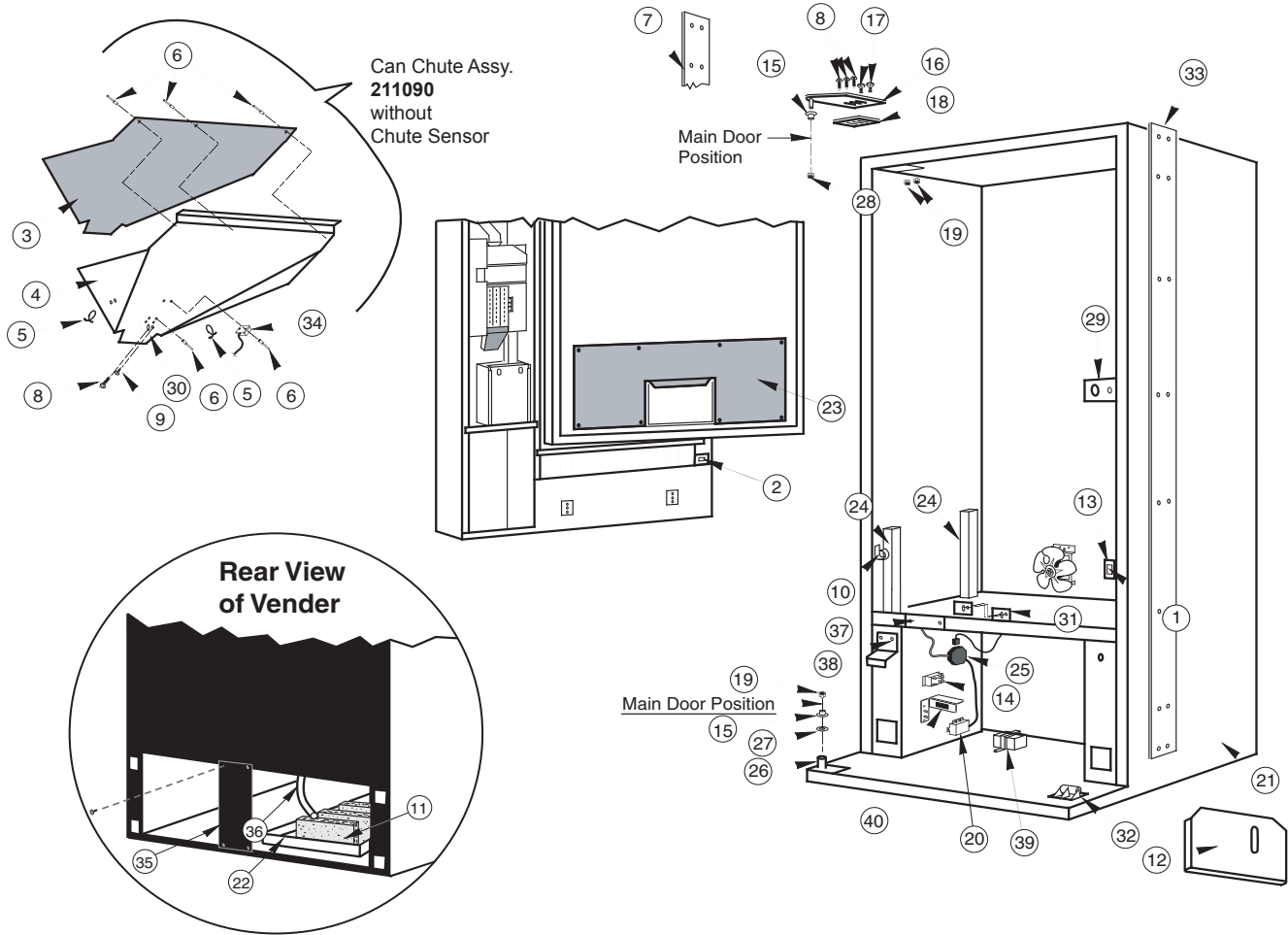

Cabinet Back Screen Mesh, Wide, 141001  
 -Narrow, 258004  
 Cabinet Back Screen Steel, Wide, 010215  
 -Narrow, 258005

\*Specify Colour



# SECTION 7: EXPLODED VIEWS

## Cabinet Assembly

Item No.	Description	Part No.
1	Door Switch (Prior to 1521)	835003
2	Door Switch (1521 & after)	835019
3	Delivery Chute Liner	815261
4	Delivery Chute	210002
5	Clip, Tension	916059
6	Rivets, 1/8"	908004
7	*Left Vandel Panel 72"	142001
	* - 79"	141002
8	Bolt, 1/4"-20 x 1"	901003
9	Screw, #8-18 x 1/2"	902004
10	Cable Clamp	916004
11	Sponge	815037
12	Condenser Baffle	010403
13	Bracket, Door Switch	010045
14	Relay	836130
15	Bushing, Nyliner	916012
16	Hinge, Top Left	810002
17	Bolt, Carriage, 1/4" - 20 x 1"	901008
18	Spacer, Top Hinge	010016
19	Keps Nut, 1/4"-20	905002
20	EMI Filter	842061
21	Cabinet Assy., 79.5"	210010
	- 72"	211001
22	Condensate Pan	815368
23	Inner Door Cover Assy.	815259
24	Support, Rack	281001
25	Main Wiring Harness	
	- Italy / Chile	842162
	- Cont. Europe (Schuko)	842163
	- Australia / New Zealand	842164
	- UK / Ireland / Gibraltar / Hong Kong	842166
	- South Africa / India	842206
	- Denmark	842222
26	Hinge, Bottom Main Door	010040
27	Washer, Flat	904002
28	Keps Nut, 3/8"-16	905007
29	Latch Strike Assy.	010030
	- After 1530	281010
30	Bracket, Chute Locator	095002
31	Bracket, Cabinet Chute	010017
32	Door Roller Kit	141180
33	*Vandal Panel, Cabinet, Right, 79.5"	012122
	* - 72"	011002
34	Chute Sensor, Cabinet Side	210121
35	Rear Baffle	010037
36	Drain Tube	815134
37	Wiring Cover Plate	010002
38	Door Switch Actuator	231009
39	Transformer - 230V 50 Hz	842220
	- Australia / New Zealand / Northern Ireland	842221
40	IEC Fuse Box Bracket	010087
	- Fuse Box Assembly	842219
	• Harness, Filter to Trans.	286540
	• Drain Pan Hose Clip	906025
	• Transformer Cover IEC	258003

# SECTION 7: EXPLODED VIEWS

## Narrow Port Assembly

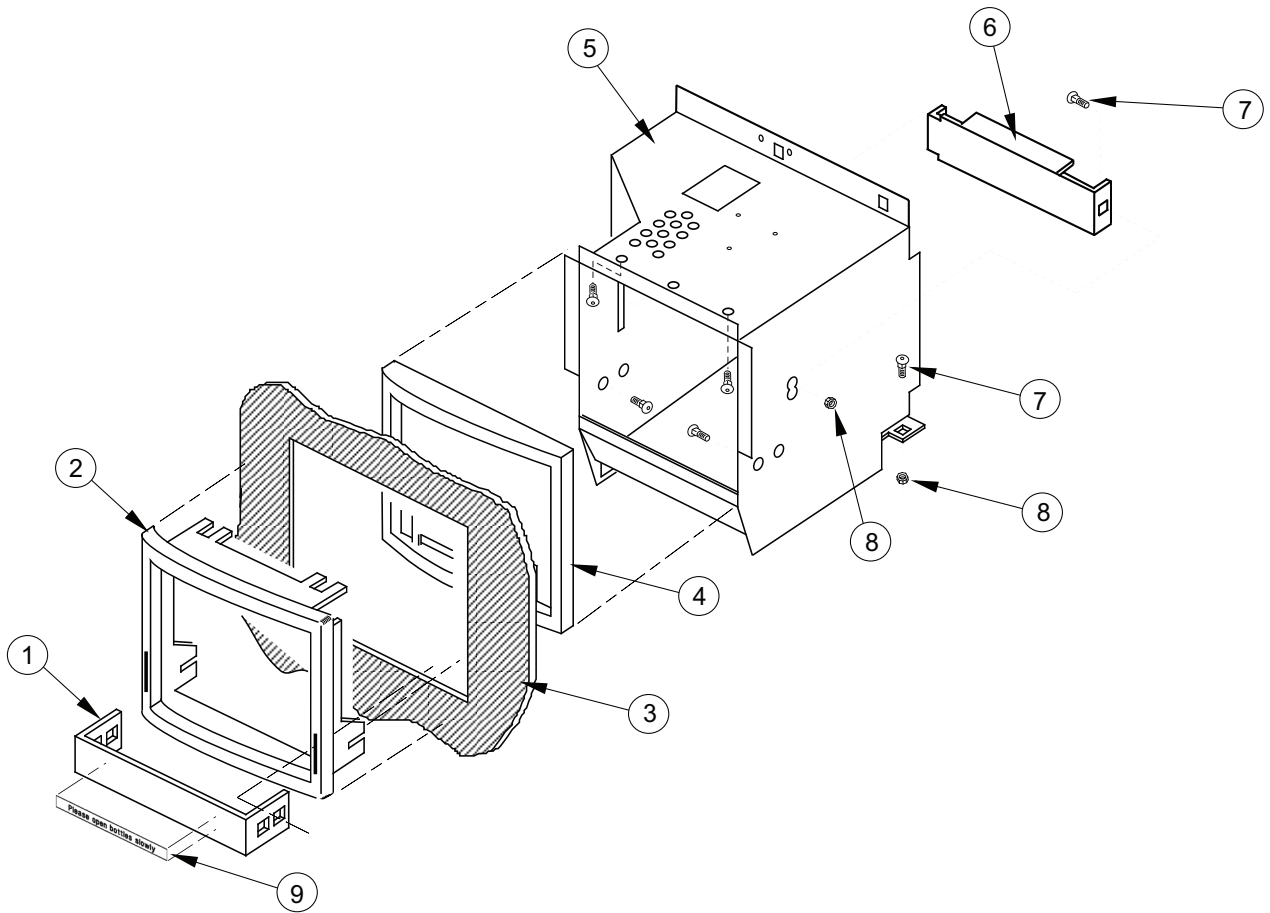

Item No.	Description	Part Number	Qty.
1	Package Stop	010508	1
2	Port Trim	815019	1
3	Sign	Contact RV Customer Service	1
4	Port Spacer	815020	1
5	Port Body Assy., Welded	210510	1
	-Marketing	290540	1
6	Anti-theft Plate, CDC with EMS Motion Sensor	231593	1
	-Non CDC	210505	1
	-CDC	231523	1
	-CDC, Narrow Vender	231504	1
	-Marketing	290519	1
7	Bolt, 1/4-20 x 1/2"	901007	9
8	Nut, 1/4-20	905002	9
9	Anti-Foaming Label, English	931260	1
	- French	931309	1
	- Spanish	931310	1
	- Danish	931316	1

# SECTION 7: EXPLODED VIEWS

## Wide Port Assembly

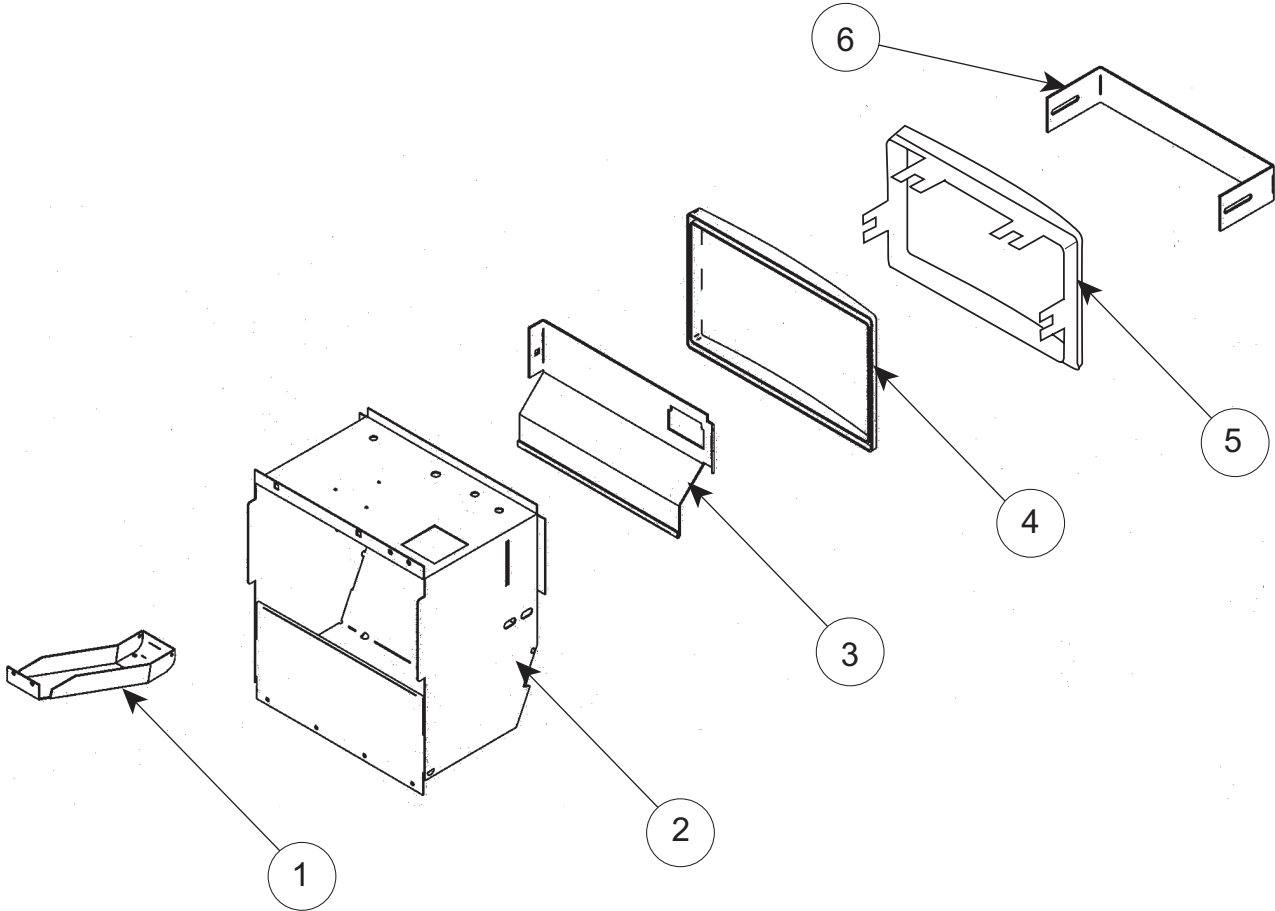

Item No.	Description	Part Number	Qty.
1	Coin Cup	231505	1
2	Port Body Assy., Welded	303540	1
	-Non CDC	305510	1
3	Anti-theft Plate,		
	CDC with Motion Sensor	303541	1
	-CDC without Motion Sensor	303503	1
	-Non CDC	305501	1
4	Port Spacer	815248	1
5	Port Trim	815249	1
6	Package Stop	273508	1

# SECTION 7: EXPLODED VIEWS

## Inner Door Assembly

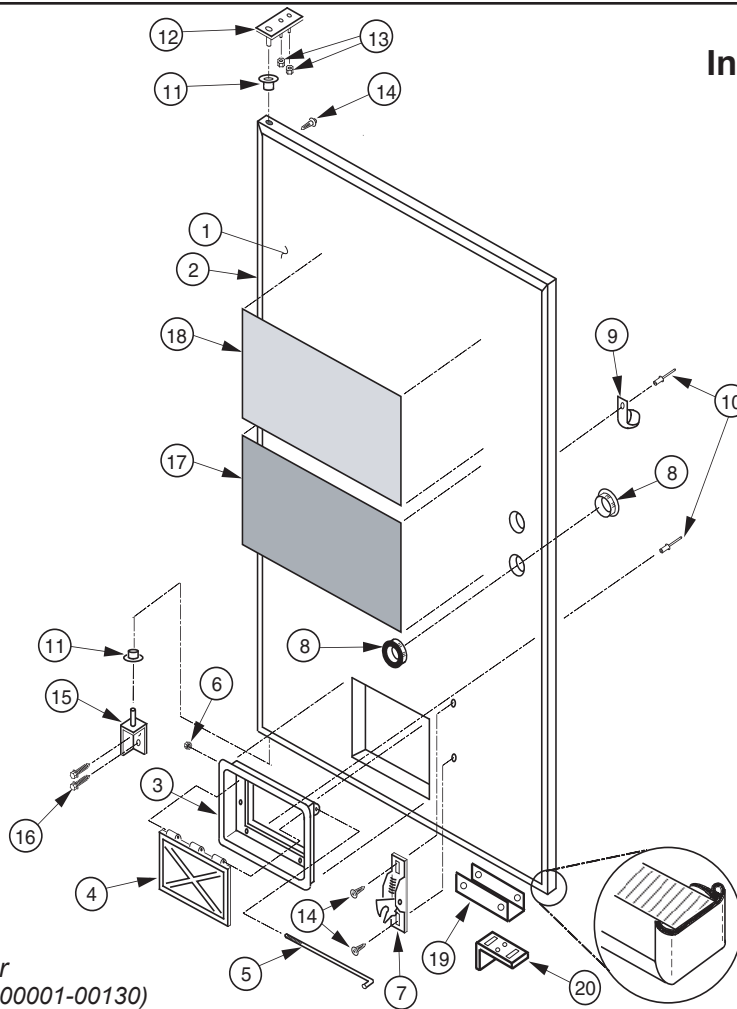

\*1504 & after  
(except 1504-00001-00130)

Item No.	Description	Part Number	Qty.
1	Inner Door Assy, IEC, 72"	211606	1
	-79"	210607	1
	-79" Marketing*	290606	1
	-72" Narrow*	289531	1
	-72" Marketing*	291606	1
	-72" Narrow Marketing*	293607	1
	Gasket, Inner Door, 72"	815032	1
2	-79.5"	815033	1
3	Port Door Frame	815191	1
4	Port Door	815192	1
5	Port Door Rod	811028	1
6	Lock Nut, #6-32	905006	1
3-6	Port Door Assy	810053	1
7	Burst Open Latch	812002	1
8	Bushing, 1.38"	916003	2
9	Clamp, Cable, 1"	916004	1
10	Rivet, 3/16" Diameter	908002	2
11	Bushing, Inner Door	815026	2
12	Hinge, Inner Door (Top)	010520	1
13	Nut, #8-32	905001	2
14	Screw, Self-drilling, #8-18x1/2"	902001	50
15	Hinge, Bottom, Door	010550	1
16	Bolt, 1/4-20x1"	901003	2
17	Interconnect Decal, G-III I.E.C., English	931488	1
18	- Spanish	931489	1
	- French	931504	1
	Vender Controller Decal, G-III E.V.S., English	931352	1
19	-Spanish	931380	1
	- French	931381	1
	IEC Saddle	141131	1
20	IEC Switch Activator	141602	1

# SECTION 7: EXPLODED VIEWS

## Evaporator Fan Motor Assembly

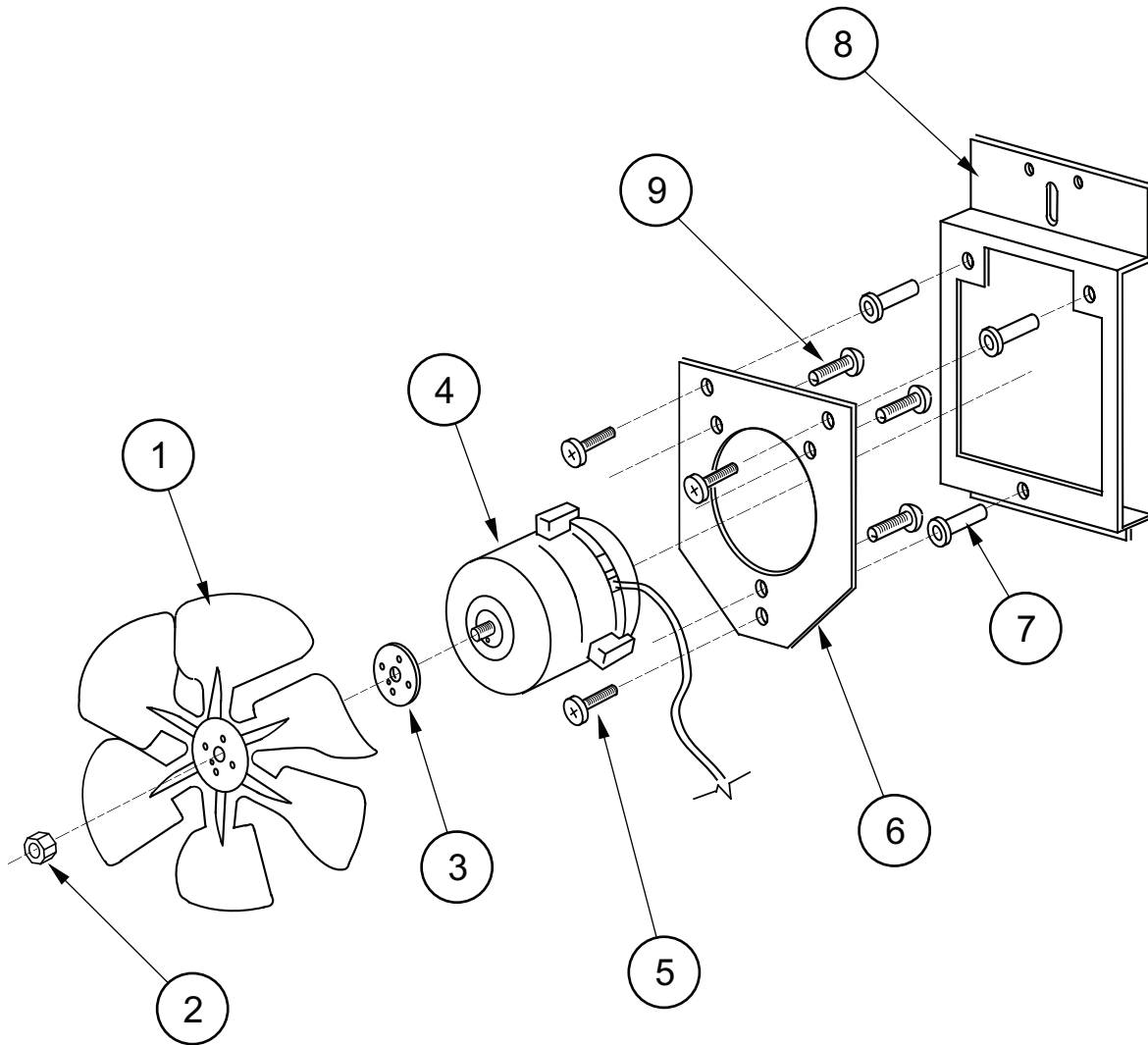

Item No.	Description	Part Number	Qty.
1	Fan Blade	810077	1
2	Nut, 1/4-20	905002	1
3	Silencer	939037	1
4	Motor, 25.6 W, 230 VAC	839034	1
5	Machine Screw #8-32x1/2"	901038	3
6	Fan Plate	010058	1
7	Well Nut, #8-32	905026	3
8	Fan Mounting Bracket	010057	1
9	Sems Screw #8-32x3/8"	901011	3
1-9	Fan Assembly, 230 VAC - Energy Efficient Fan (one complete assembly)	303122 337050	1 1

# SECTION 7: EXPLODED VIEWS

## Vend Mechanism Assembly

Prior to 1504

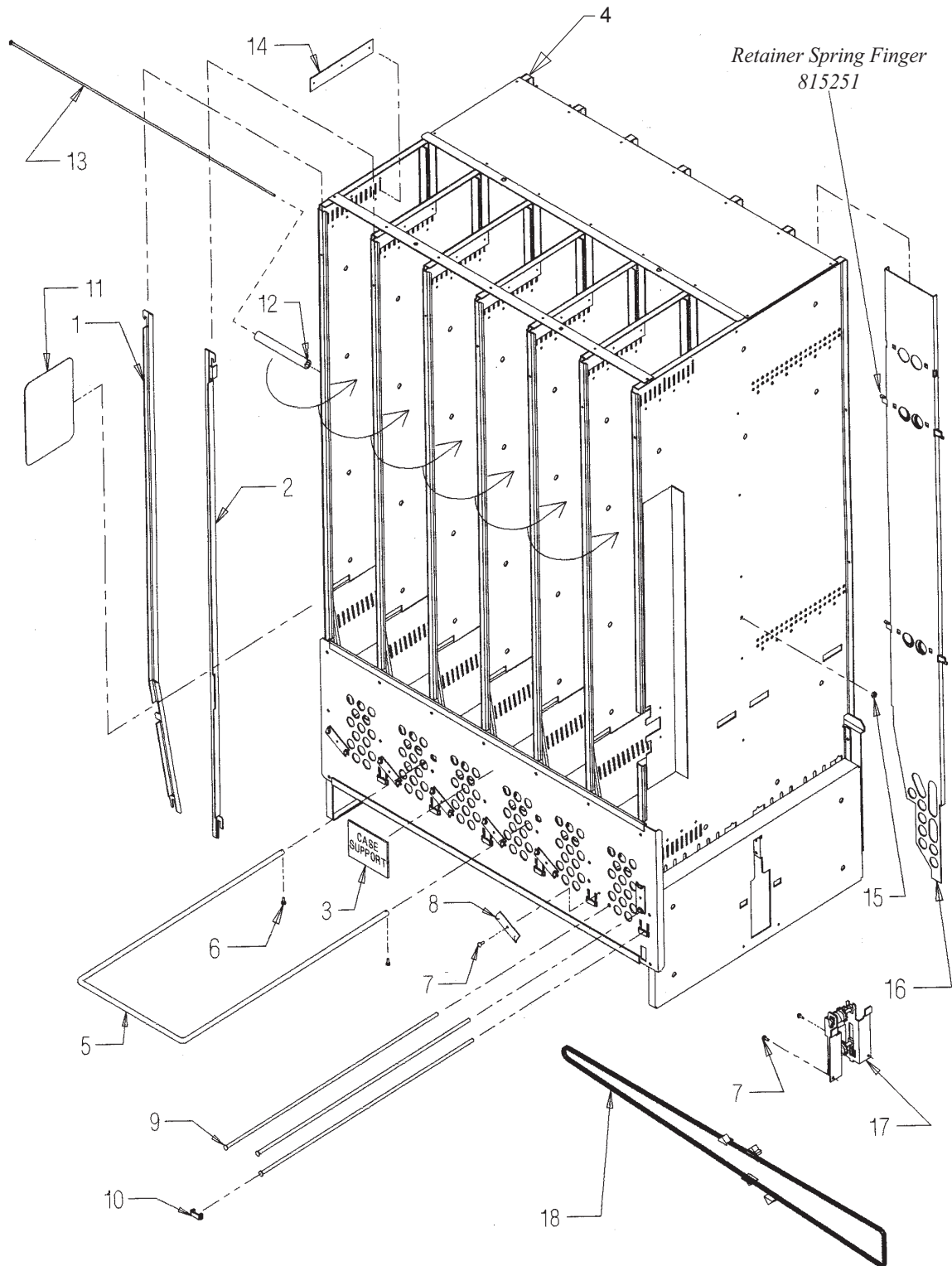

# SECTION 7: EXPLODED VIEWS

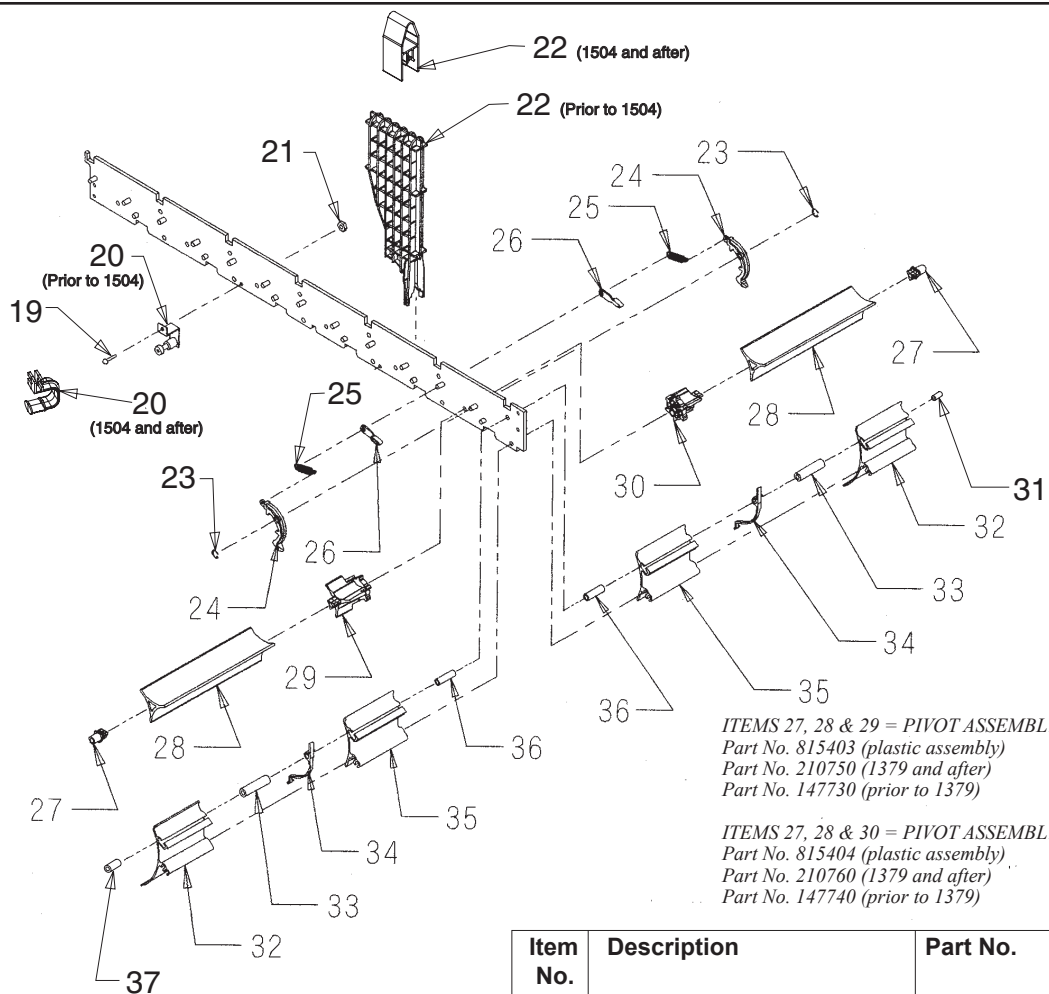

ITEMS 27, 28 & 29 = PIVOT ASSEMBLY, FRONT  
 Part No. 815403 (plastic assembly)  
 Part No. 210750 (1379 and after)  
 Part No. 147730 (prior to 1379)

ITEMS 27, 28 & 30 = PIVOT ASSEMBLY, REAR  
 Part No. 815404 (plastic assembly)  
 Part No. 210760 (1379 and after)  
 Part No. 147740 (prior to 1379)

**\*\*1504 & after (except 1504-0001-00130)**

Item No.	Description	Part No.	Qty.
1	Retainer, Front, L, 79.5 - 72"	210745 211712	6 6
2	Retainer, Front, R, 79.5" -72"	210746 211713	6 6
3	Case Support Decal, Eng. - Spanish	931195 931280	1 1
	- French	931375	1
4	Vend Stack Assembly 79.5 -72	210725 211711	1 1
5	Case Support	811026	1
6	Screw, Self-drilling*	902004	2
7	Screw, #8-32x3/8"	901011	11
8	Rod Retainer, Rotating	810046	7
9	Shaft, Pivot/Product Stop	803032	18
10	Rod Retainer, Sliding	915184	6
11	Sheet, Anti-friction	915197	24
12	Spacer, Column	915194	6
13	Bolt, Rack Retainer	811027	1
14	Rubber Strip	915199	7
15	Lock Nut, Retainer, #8-32	905004	1
16	Retainer Assy., Rear, 79.5" - 72"	210707 211709	6 6
17	Idle Bracket Assembly	210726	1
18	Chain/Actuator Assembly	210730	1

Item No.	Description	Part No.	Qty.
19	Screw, Stab., #6-32x1.5" (prior to 1504)	901023	2
	-**Screw 1.25" (1504 & after)	901041	2
20	Stabiliser Assembly (prior to 1504)	210744	2
	-**Stabiliser (1504 & after)	915266	2
21	Lock Nut, Stabiliser, #6-32 (prior to 1504)	905006	2
	-**Nut (1504 & after)	905018	2
22	Insert, Divider (prior to 1504)	815242	12
	-**Insert, Divider (1504 & after)	815252	12
23	E-ring, Release Lever	906013	12
24	Release Lever	915125	12
25	Spring, Release Lever	914008	12
26	Pawl, Anti-Rotation	915188	12
27	Bearing, Pivot	915206	12
28	Pivot	813010	12
29	Pivot End, Front	915207	6
30	Pivot End, Rear	915208	6
31	Spacer, Prod. Stop, .5"	915181	6
32	Product Stop, Long Adjustable	813016	12
33	Spacer, Prod. Stop, 1.85"	915250	12
34	Spring, Anti-tilt	915186	12
35	Product Stop, Short Adjustable	813006	12
36	Spacer, Prod. Stop, 1.25"	915182	12
37	Spacer, Front, 1"	915264	12

\*Clip, Hitch-pin (part no. 906023) in units 1435 and after.

# SECTION 7: EXPLODED VIEWS

## Vend Mechanism Assembly 1504 and after: (except 1504-00001-00130)

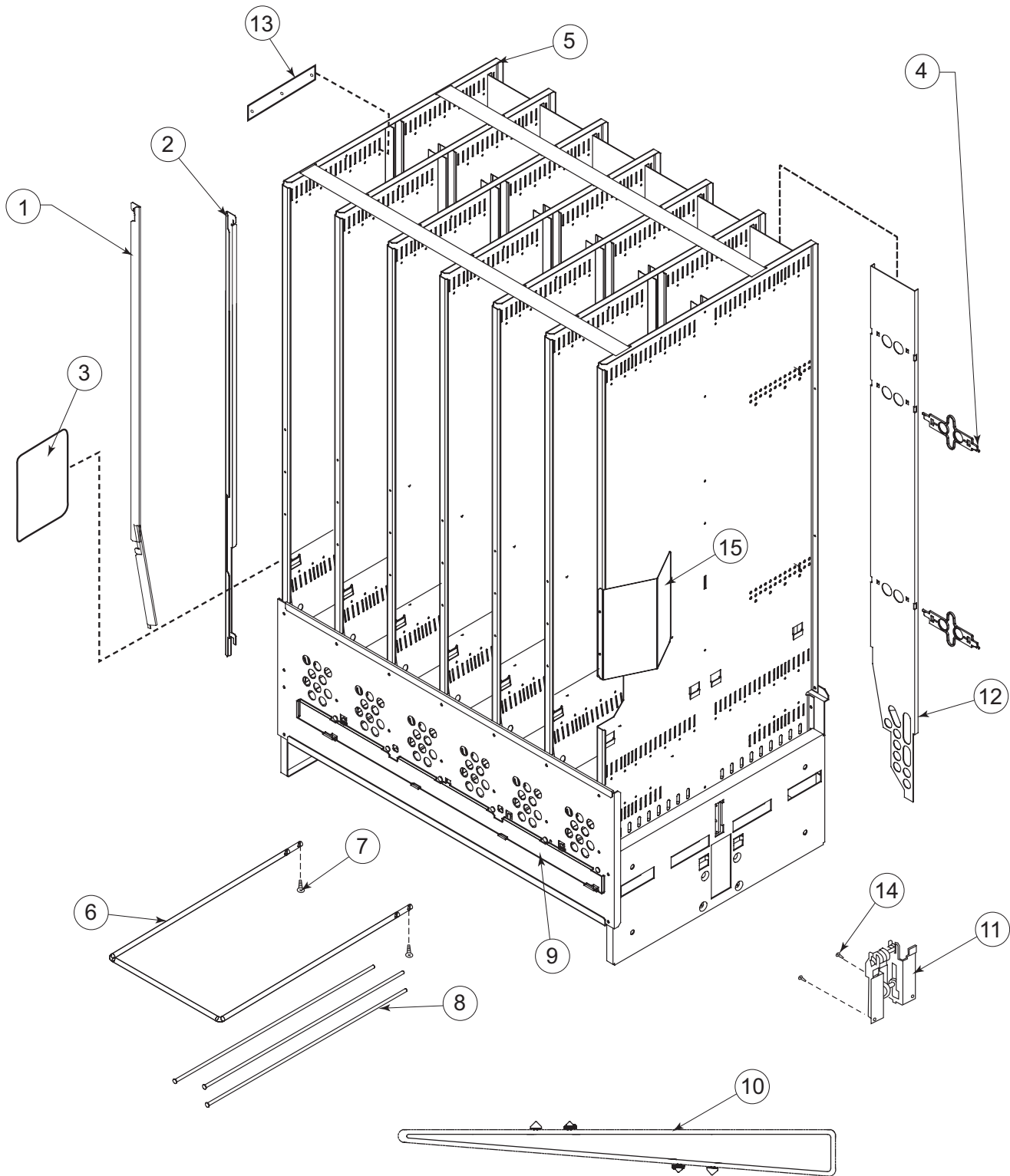



## SECTION 7: EXPLODED VIEWS

---

### 1504 and after:

*(except 1504-00001-00130)*

Item No.	Description	Part No.	Qty.
1	Retainer, Front, L, 79.5" - 72"	210745 211712	6 6
2	Retainer, Front, R, 79.5" -72"	210746 211713	6 6
3	Sheet, Anti-friction	915197	24
4	Retainer Spring Finger	815251	12
5	Vend Stack Assy, 79.5 -72	210738 211711	1 1
	-72 Narrow	289710	1
6	Case Support	811026	1
7	Screw	902004	2
8	Shaft, Pivot/Product Stop	803032	18
9	Rod Retainer	281709	1
	-Narrow	283704	1
10	Chain/Actuator Assembly, Wide Vender	281710	1
	-Narrow Vender	283710	1
11	Idler Bracket Assembly	210757	1
12	Retainer Assy., Rear, 79.5" -72	210707 211709	6 6
13	Rubber Strip	915199	7
14	Screw, #8-32x3/8"	901011	4
15	Stack Stiffener, Wide	281704	1
	-Narrow	283702	1

# SECTION 7: EXPLODED VIEWS

## Vend Motor Assembly

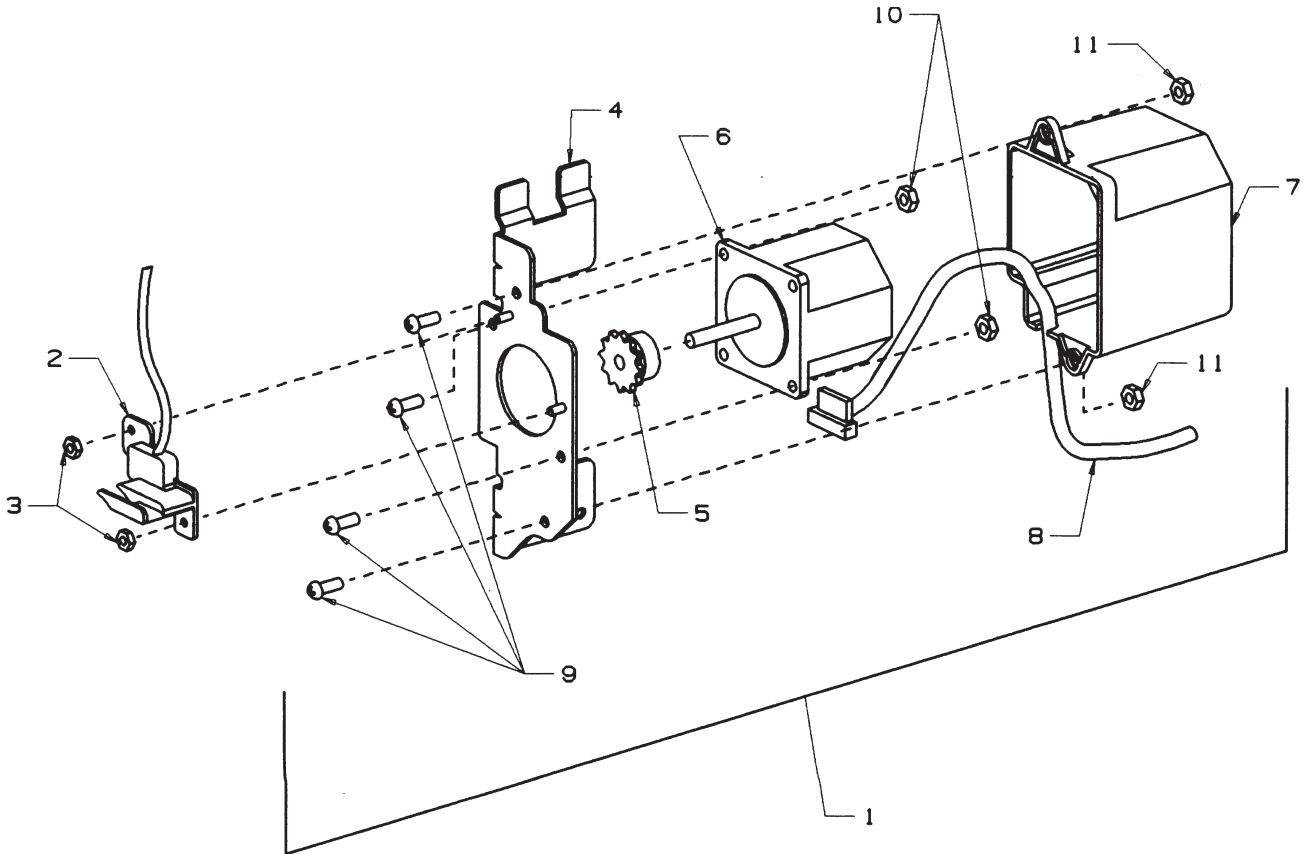

Item No.	Description	Part Number	Qty.
1	Vend Motor Assembly	210727	1
2	Home Sensor Assembly	842052	1
3	Lock Nut, Home Sensor, #6-32	905006	2
4	Bracket, Motor	----	1
5	Sprocket	916034	1
6	Motor and Encoder	----	1
7	Cover, Motor	----	1
8	Harness, Motor/Encoder	----	1
9	Screw, Machine, #10-24x.50"	----	4
10	Nut, #10-24	----	2
11	Lock Nut, #10-24	----	2

# SECTION 7: EXPLODED VIEWS

## Idler Bracket Assembly

210726 (Before run 1504)

\*210757 (1504 and after)

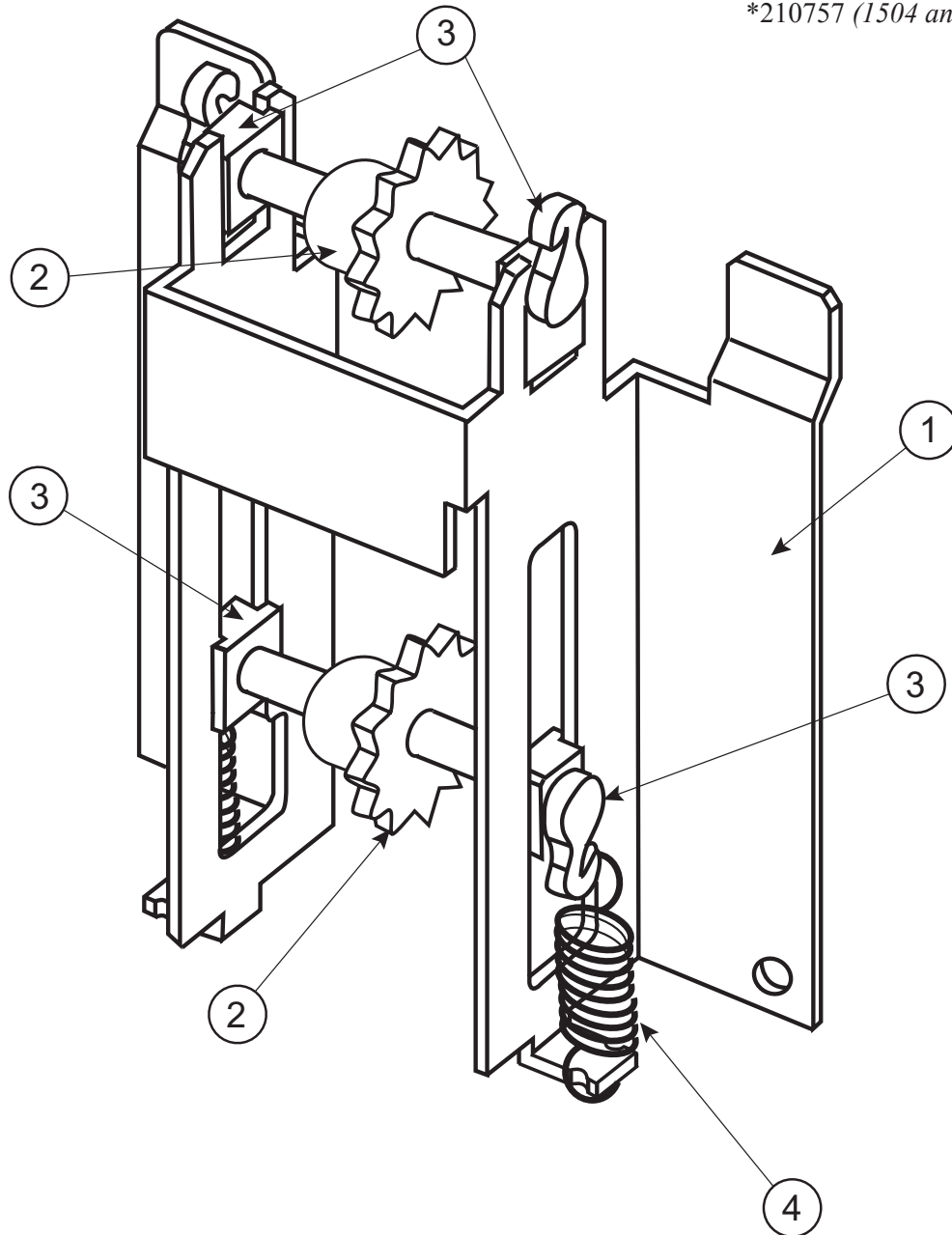

\*1504 and after (except 1504-00001-00130)

Item No.	Description	Part Number	Qty.
1	Bracket, Idler (before run 1504)	210703	1
	-*Bracket, Idler (1504 & after)	281713	1
2	Shaft/Sprocket, Idler Assy (Before run 1504)	095770	2
	-*Shaft/Sprocket, Idler Assy (1504 & after)	281716	2
3	Bearing, Idler Shaft	915079	4
4	Spring, Idler	914021	2

# SECTION 7: EXPLODED VIEWS

## Select Panel Assembly

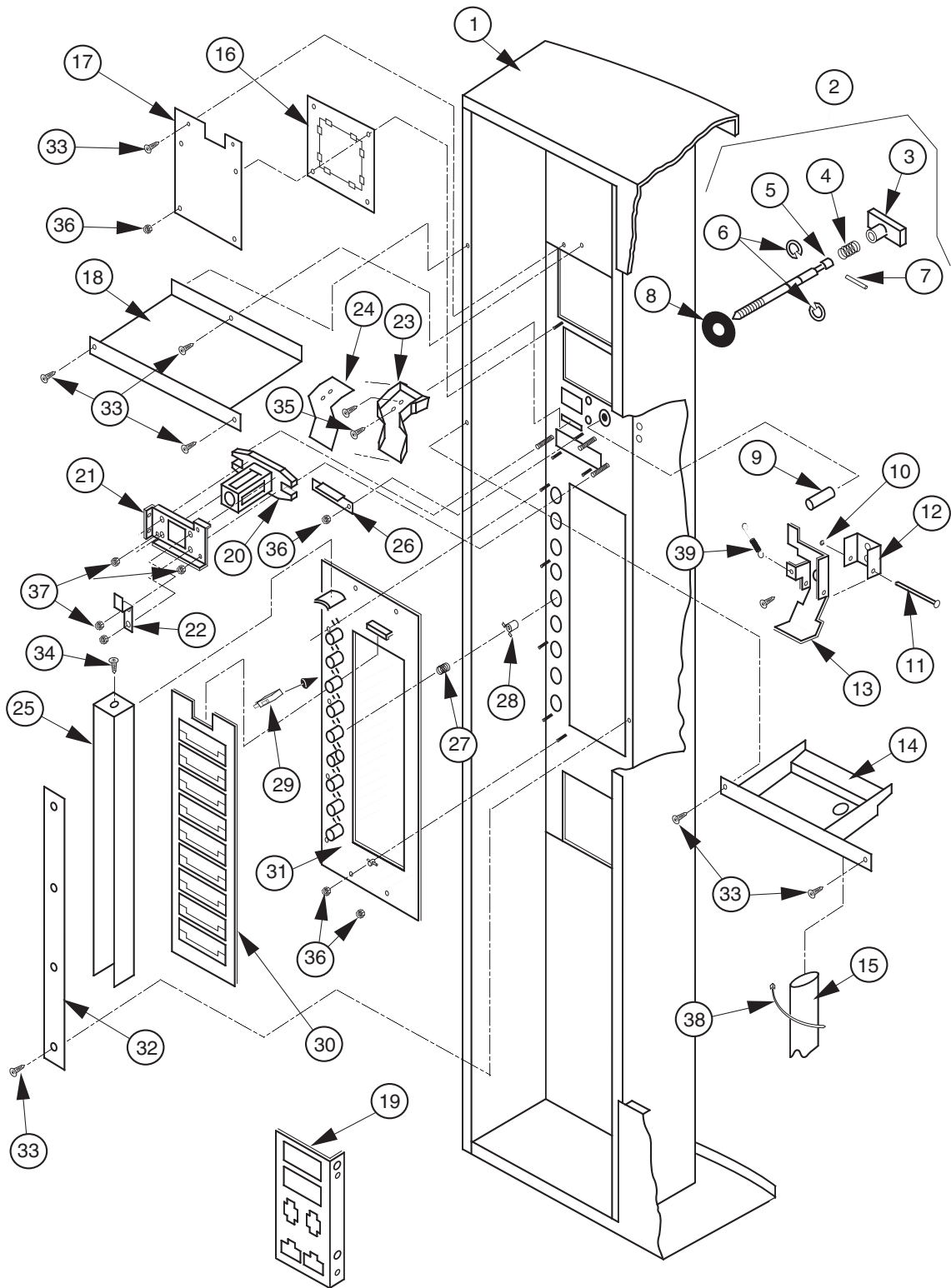

# SECTION 7: EXPLODED VIEWS

## Select Panel Assembly

\*1504 and after

(except 1504-00001-00130)

Item No.	Description	Part Number
1	Welded Assy., 79"	141510
	-72"	142510
	- 79" Narrow	258510
	- 72" Gas Island	285510
2	T-Handle Assy. (Items 3, 4, 5, 6, 7 & 20)	
	Flush Mount Pop-Out	812176
	-*T-Handle Assy.	812289
	-*T-Handle Assy, Stainless	812291
3	T-Handle Body	n/a
4	T-handle Spring, 1.75"	914048
5	T-Handle Stud	803006
6	Retaining Ring	912157
7	Pin/T Handle Stud	n/a
8	T-Stud Sealer Washer	915258
9	Button, Coin Return Lever	803031
10	Retaining Ring, 5-32"	906005
11	Roller Pin - Door Lifter	811002
12	Hinge - Coin Return Lever	141506
13	Coin Return Lever	141504
14	Catch Basin	095590
15	Catch Basin Drain Tube	925038
16	P.O.S. Window - Coke	815007
17	P.O.S. Window Plate	123503
18	Security Shelf	141512
19	Fuse Bracket I.E.C.	141522
20	T-Handle Housing	812190
21	T-Handle Brace	141513
22	Lever Stop	141514
23	Coin Chute	815001

Item No.	Description	Part Number
24	Coin Chute Cover	815002
25	Splash Guard - Coke	815169
26	Coin Ramp	141508
27	Spring-Select Button	914004
28	Select Button - Coke	815165
29	Switch, Miniature	835001
30	Carrier Strip Assy.	815167
31	Button Panel	815168
32	Retaining Strap	141507
33	Sems Screw, #8-32x3/8"	901011
34	Screw, Self-drilling #8x1/2" w/ 1/2" Washer	902001
35	Sew Screw #6-32x3/8"	901004
36	Nuts, Keps #8-32	905001
37	Nuts, Keps 1/4-20	905002
38	Wire Tie, Large (10 cm)	916007
39	Sold Out Spring	914003
•	Bottom Coin Chute Assy	
•	Non CDC (Landscape) Coin return:	010594
	-Bushing (Coin return)	803030
	-Hex Jam Nut (Coin return)	905019
	-9/16 Internal Tooth Washer (Coin return)	904013
•	PC Board Housing	095530
•	Splash Guard	815169
•	Hole-Block Lock Cover	141509

# SECTION 7: EXPLODED VIEWS

## Refrigeration Unit 210402

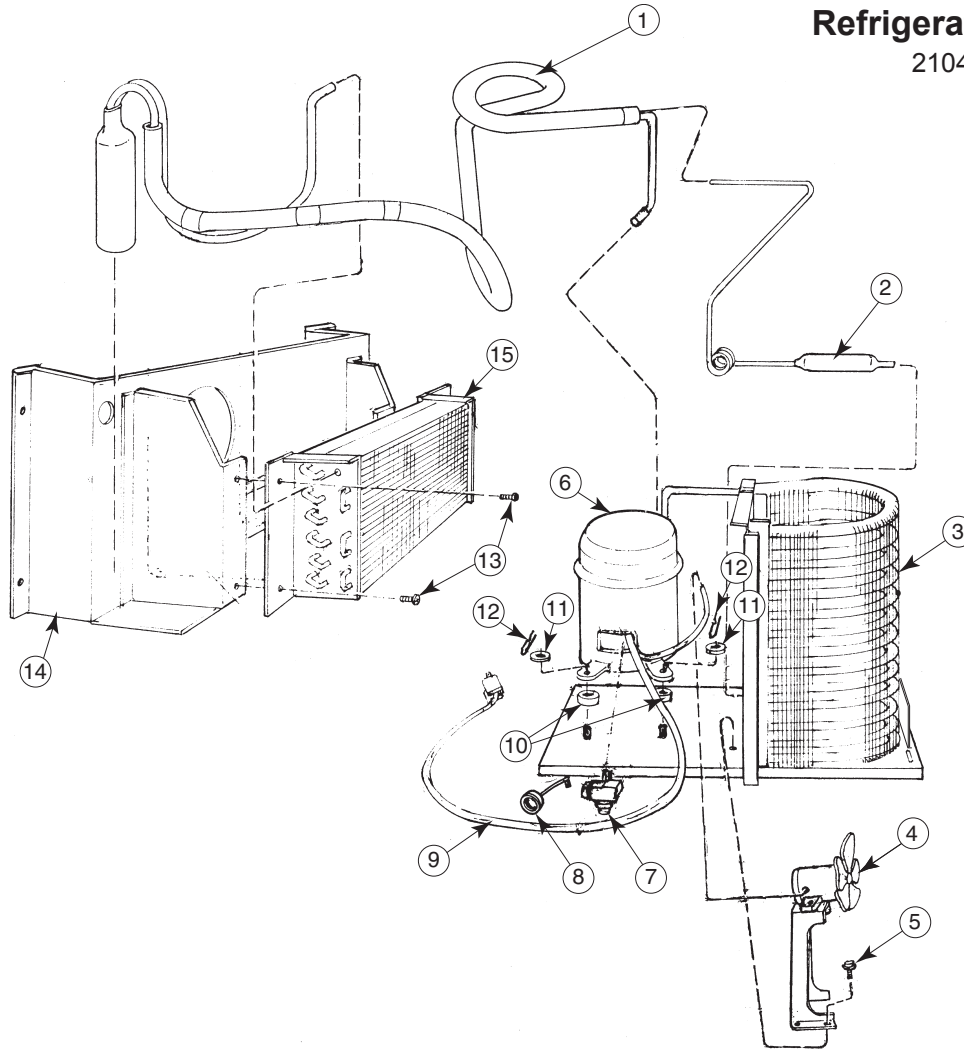

Item No.	Description	Part Number	Qty.
1	Heat Exchange	See Note #1	1
2	Dryer	824005	1
3	Condenser	820007	1
4	Condenser Motor, 230 VAC (Blade Only)	839019 (810014)	1
5	Screw, #8-32x1/2	901006	2
6	Capstart Compressor, 1/3+ Tecumseh, 230 VAC, R134a	819046	1
7	Relay, Tecumseh, 230 VAC	822040	1
8	Overload, 230 VAC	822039	1
9	Compressor Lead	See Note #1	
10	Grommets, Compressor	916015	4
11	Grommet Plug	815017	4
12	Clip, Compressor	914002	4
13	Screw #8x1/2	902004	4
14	Fan Shroud Assy.	210088	1
15	Evaporator Coil	820002	1
•	Evaporator Cover	210007	1
•	Refrigeration Base Plate	010405	1

**Note #1:** This part is not available individually. It must be ordered as an assembly.

# SECTION 7: EXPLODED VIEWS

## Vandal-Resistant Door

Control Panel, 9 Sel, W/A CDC  
163520 (Before 1525)

Control Panel, 7 Sel, W/A CDC  
161530 (Before 1525)

Control Panel, 9 Sel, CDC  
163580 (1525 & after)

Control Panel, 7 Sel, CDC  
161577 (1525 & after)

Security Plate, W/A CDC  
161550

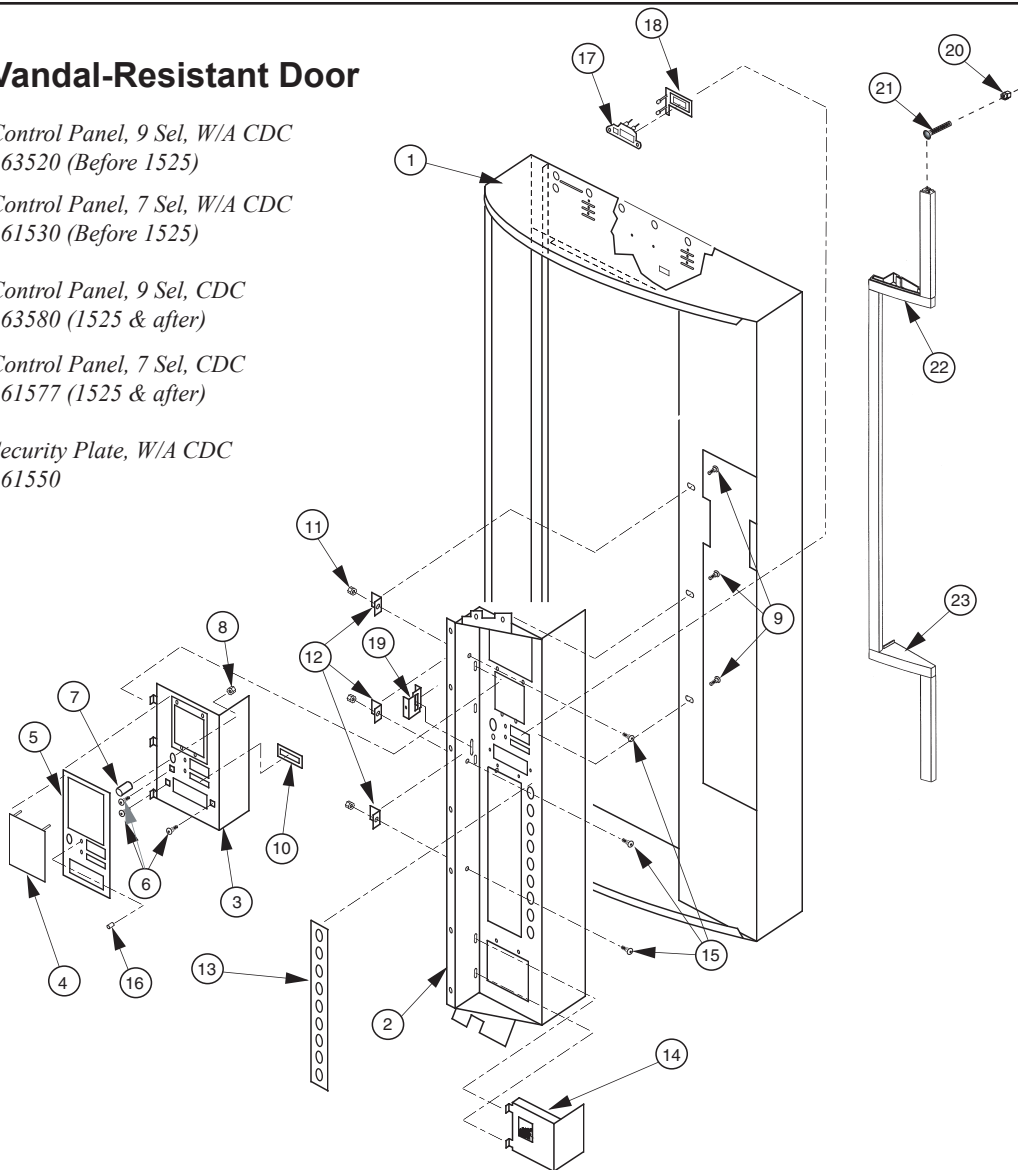

Item No.	Description	Part Number
1	Door W/A Coke 79" Wide	141510
	- 72" Wide	142510
	- 72" Narrow	149510
2	Control Panel, 9 Select (Before 1525)	143510
	- 7 Select, Narrow (Before 1525)	141530
	- 9 Select (1525 and after)	143507
	- 7 Select, Narrow (1525 and after)	141577
3	Security Plate W/A	141550
4	Banknote Acceptor Cover, Coke	010535
5	Security Plate Decal - English	845467
	- Spanish	845447
	- Portuguese	845471
	- Dutch	845606
	- French	845937
6	T-bolt, 1/4-20x1" LG	901037
7	Button, Coin Return Lever	803031
8	Hex Jam Nut 9/16-18 UNF2A	905019

Item No.	Description	Part Number
9	Sems Screw, #8-32x3/8" LG	901011
10	Coin Plate, Coke - Export	141511
11	Keps Nut, 1/4-20	905002
12	Hold-Down Angle	123505
13	Decal Select Button	845383
14	Coin Cup Mounting Plate W/A	123550
15	Carriage Bolt, 1/4-20x1/2" LG	901007
16-18	LED Assembly	010593
19	Lock Cover Hole Block	141509
20	Keps Nut	905001
21	T-Screw	901001
22	Coke Trim Filler, Top	815311
23	Coke Trim Filler, Bottom	815312
•	Bottom Coin Chute Assy, Non CDC	010594
•	Ballast Assy, Non-CDC 230 VAC	281510
•	Ballast Assy, 72" CDC 230 VAC	231562
•	Ballast Assy, 79" CDC 230 VAC	231569
•	Tie Rod	811001

# SECTION 7: EXPLODED VIEWS

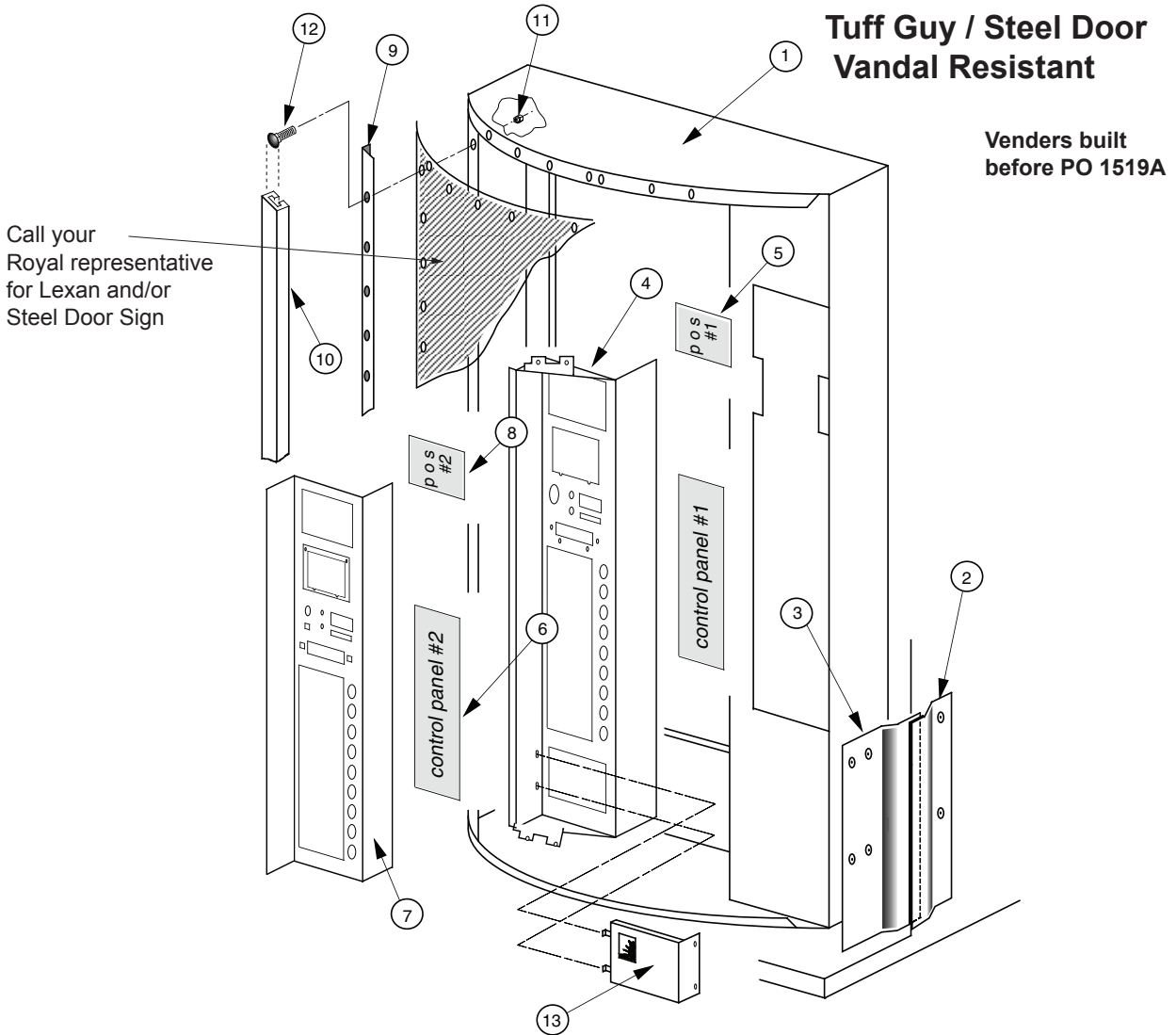

Item No.	Description	Part Number
1	Door Weld Assy., 79" -72"	141510 142510
2	Vandal Panel Cover, 79.5" -72"	171101 172001
3	*Right Vandal Panel, 79" *- 72"	010519 011501
4	Bolt On Control Panel, 9 Sel. - 7 Sel.	143510 141530
5	P.O.S. Window	815007
6	Lexan Panel - flavour card	171522
7	Front Security Plate, 9 Sel. Front Security Plate, 7 Sel.	183510 181510
8	P.O.S. Lexan Cover	171523

Item No.	Description	Part Number
9	Metal Bolt On Trim: Top and Bottom/All Wide Left, 79.5"	171502 171507
	Top and Bottom Right, 79.5" Top and Bottom/Enclosure, 79.5"	171505 171512
10	Plastic Trim: Top and Bottom/All Wide Top Right, 79.5"	171518 171516
	Top and Bottom/Enclosure, 79.5"	171519
	Bottom Right, 79.5"	171517
	Left Trim, 79.5"	171514
11	1/4-20 Keps Nut (Attaches to Item 12)	905002
12	1/2-20X 1" T-Bolt	901037
13	Coin Cup W/A	123550

**NOTES:** 1. For other trim and door sizes, contact your local Royal Vendors' representative.

2. \*Specify Colour



# SECTION 7: EXPLODED VIEWS

## Tuff Guy / Steel Door Centre Door Changer

Venders built  
before PO 1519A

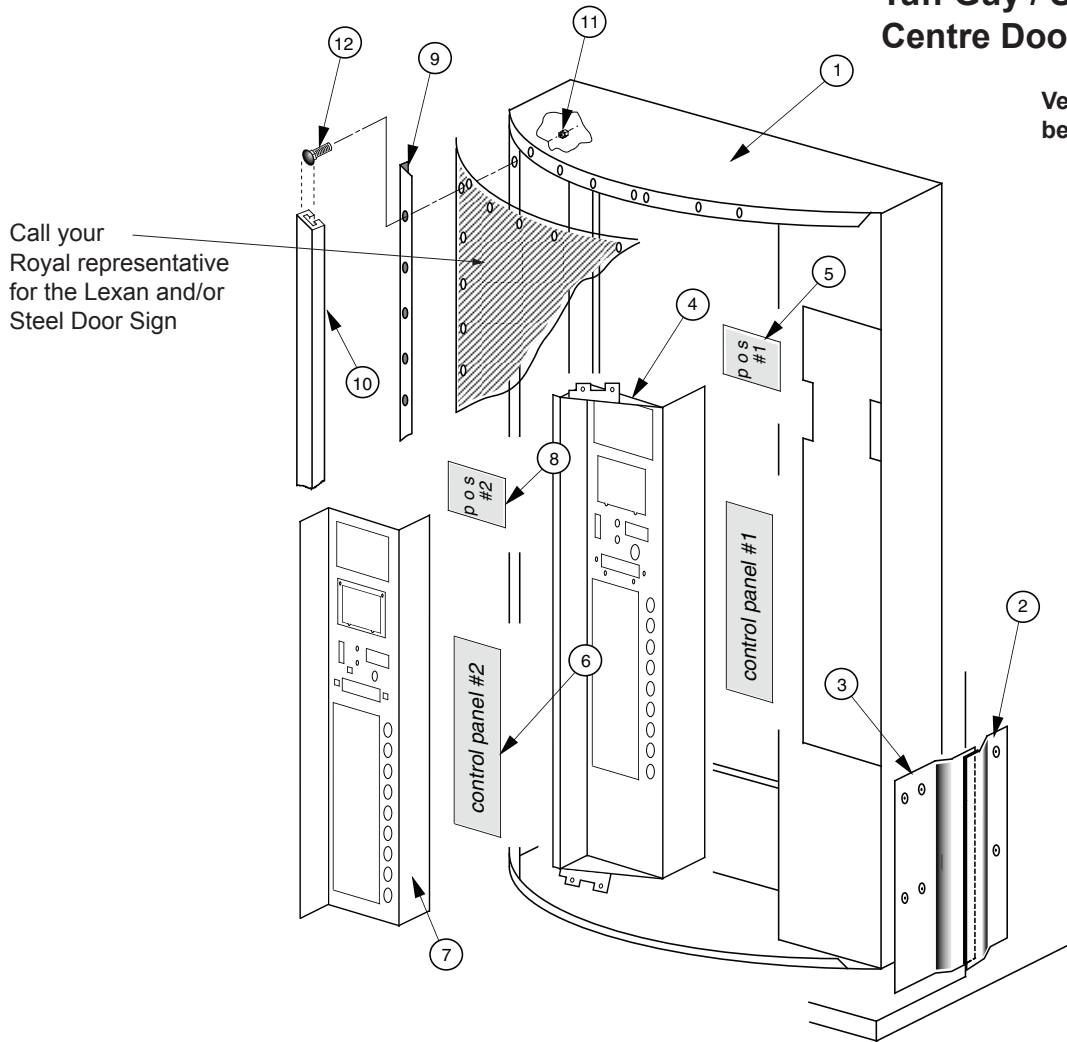

Item No.	Description	Part Number
1	Door Weld Assy., CDC, 72"	162510
	Door Weld Assy., CDC, 79"	161510
2	Vandal Panel Cover, 79.5"	171101
	Vandal Panel Cover, 72"	172001
3	*Right Vandal Panel, 79"	010519
	*Right Vandal Panel, 72"	011501
4	Bolt On Control Panel, 9 Sel., CDC	163520
	Bolt On Control Panel, 7 Sel., CDC	161530
5	P.O.S. Window	815007
6	Lexan Panel	171522
7	Front Security Plate, 9 Sel.	173510
	Front Security Plate, 7 Sel.	171510
8	P.O.S. Lexan Cover	171523

Item No.	Description	Part Number
9	Metal Bolt On Trim: Top and Bottom/All Wide	171502
	Left, 79.5"	171507
	Top and Bottom Right, 79.5"	171505
	Top and Bottom/Enclosure, 79.5"	171512
	Right Trim, 79.5"	171506
10	Plastic Trim: Top and Bottom/All Wide	171513
	Top Right, 79.5"	171516
	Top and Bottom/Enclosure, 79.5"	171512
	Bottom Right, 79.5"	171517
	Left Trim, 79.5"	171514
11	1/4-20 Keps Nut (Attaches to Item 12)	905002
12	1/4-20 x 1" T-Bolt	901037

**NOTES:** 1. For other trim and door sizes, contact your local Royal Vendors representative.

2. \*Specify Colour

# SECTION 7: EXPLODED VIEWS

## Steel Door

Venders built  
PO 1519A and after

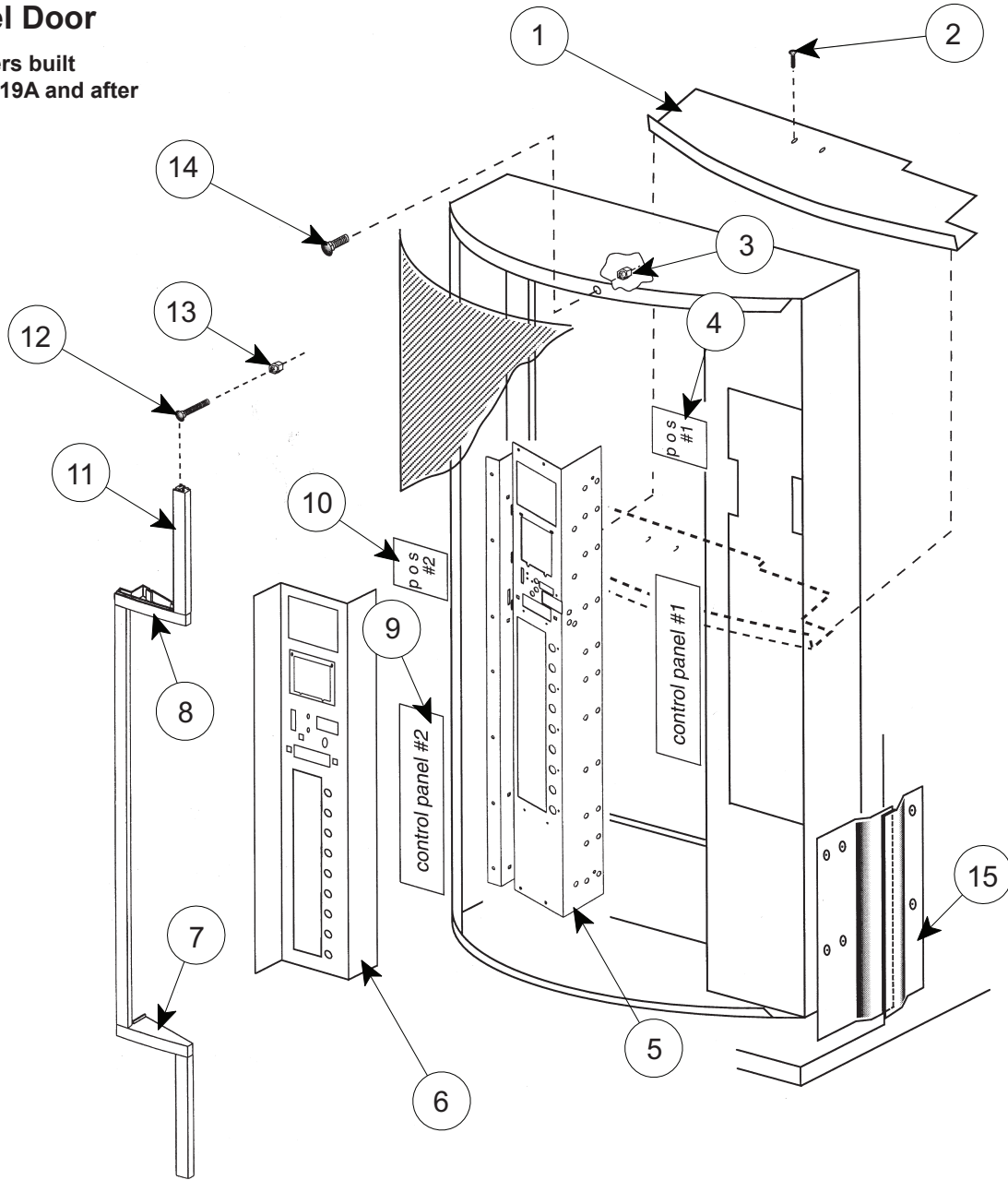

Item No.	Description	Part Number
1	Sign Support	171536
2	#8-32 Screw (2)	901011
3	1/4 Keps Nut	905002
4	P.O.S. Window	815007
5	Control Panel, 9 select	141578
	-7 select	141577
6	Front Security Plate, 9 Sel.	183510
	-7 Select	181510
7	Coke Trim Filler, Bottom	815312
8	Coke Trim Filler, Top	815311
9	Lexan Panel - Flavour Card	171522
10	P.O.S. Lexan Cover	171523

Item No.	Description	Part Number
11	Trim Kit Assembly 79"	143509
	-72"	142507
	-72" Narrow	259560
12	T-Screw	901001
13	Keps Nut	905001
14	Carriage Bolt (3 Req.)	901056
15	Vandal Panel Cover, 79"	171101
	-72"	172001

# SECTION 7: EXPLODED VIEWS

## Centre Door Changer Assembly

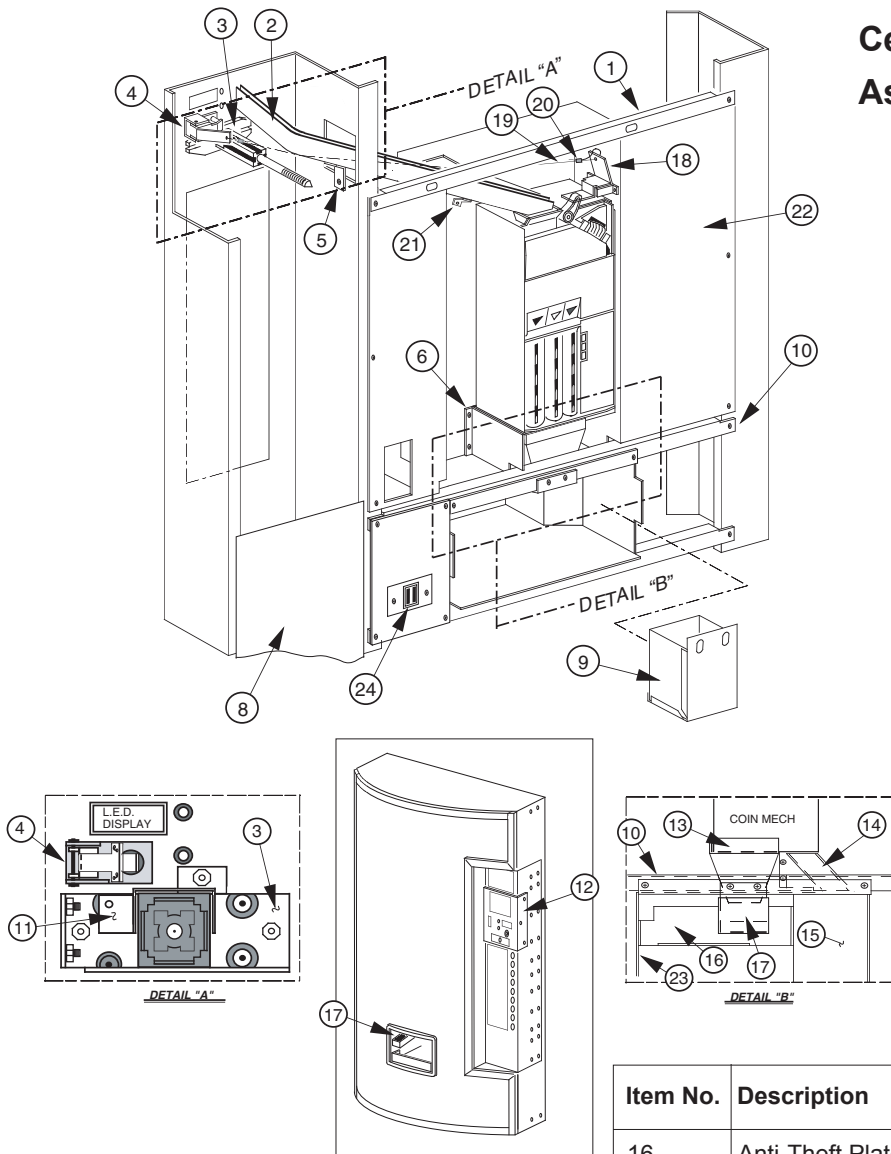

Item No.	Description	Part Number
1	Changer Vault Brace	161518
2	Coin Chute Assy., CDC, 79.5" -72"	161590 162540
3	T-Handle Brace (See Detail A)	141513
4	Button Lever Assembly	161594
5	Coin Chute Bracket, 79.5" -72"	161527 162502
6	Hopper Mounting Bracket	161515
8	Select Panel Plate	161512
9	Coin Box, CDC	815347
10	W/A Port Brace	161541
11	Lock Cylinder Cover	161532
12	Coin Insert Assembly, Coke, Electronic, CDC, 79.5" Coin Insert Assembly, Coke, Electronic, CDC, 72"	161930 162920
13	Coin Hopper	815015
14	Coin Box Coin Chute W/A	231519
15	Coin Box Housing, CDC	273503

Item No.	Description	Part Number
16	Anti-Theft Plate, CDC	231504
17	Coin Cup, CDC (1349 & after) -prior to 1349	231505 161505
18	Coin Return Lever Assembly	161593
19	3/64 Diameter Cable	911032
20	Cable Sleeve (at each end)	906015
21	Support Bracket/Coin Chute	161537
22	Changer Vault W/A	161523
23	Port W/A, CDC	231510
24	IEC Interrupt Switch	835015
•	IEC Switch Plate	141598
•	Harness, Line to Filter IEC	842292
•	Harness, Extension to Ballast	
•	Filter (plugs into 842292)	141581
•	Changer Vault Door (not shown)	161534
•	Change Label, CDC - English	931341
	- French	931308
	- Spanish	931374
•	Coin Deflector	161526

\* Coin box w/a CC CDC 15 cm = part number 161570

\* Coin box w/a GIII CDC 20 cm = 231550

\* Coin box w/a GIII Narrow = 010548

# SECTION 7: EXPLODED VIEWS

## Coca Cola Marketing Vender (Miscellaneous Assemblies)

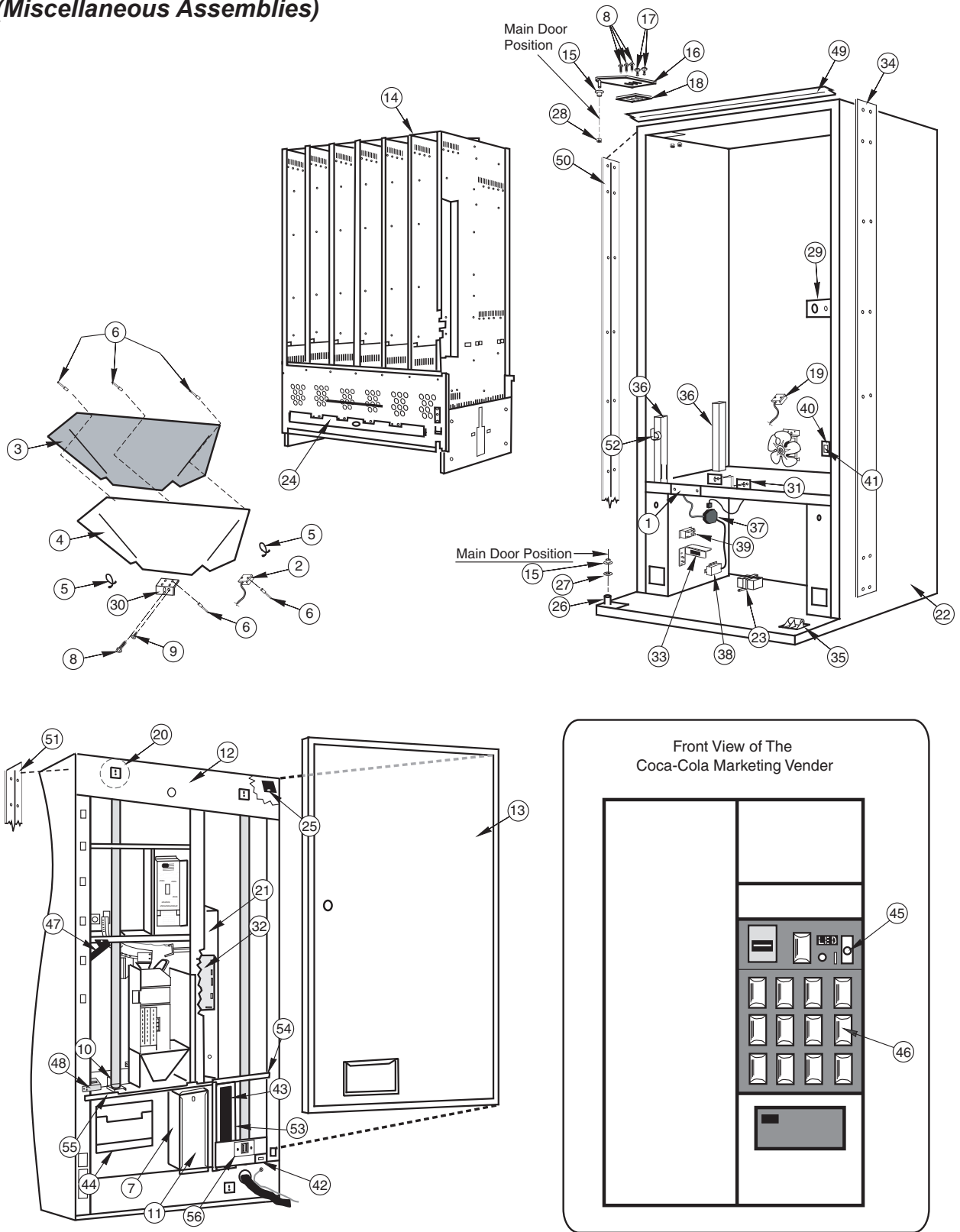

## SECTION 7: EXPLODED VIEWS

### Coca Cola Marketing Vender (*Miscellaneous Assemblies*)

Item No.	Description	Part Number	Item No.	Description	Part Number
1	Wiring Plate Cover	010002	34	Right Cabinet Vandal Panel 72" Marketing	291004
2	Delivery Chute Sensor	836108		- 79", Marketing	290004
3	Delivery Chute Liner, Wide Marketing	815299	35	Door Roller Kit	141180
4	Delivery Chute, Wide Marketing	290001	36	Rack Support	281001
5	Tension Clips	916059	37	Main Wiring Harness	
6	Rivets 1/8"	908004		- Italy / Chile	842162
7	Coin Box Housing, Marketing	290526		- Cont. Europe (Schuko)	842163
8	Bolts 1/4-20x1"	901003		- Australia / NZ / Argentina	842164
9	Screw #8-18x1/2"	902004		- UK / IRL / GIB / HK / SG / MY	842166
10	Lamp Bracket (bottom),Marketing	290534		- South Africa / India	842613
11	Coin Box, Marketing	290550		- Denmark	842222
12	Door Assembly	Contact RV Cust. Svc.	38	EMI Filter	842061
13	Inner Door Assembly, Wide Marketing 72"	291606	39	Refrigeration Relay	836130
	- Wide Marketing 79"	290606	40	Door Switch Bracket	010045
	- Narrow Marketing	289531	41	Door Switch (prior to 1521)	835003
14	Vend Rack Assembly, Marketing Wide 72"	291710	42	Door Switch (*1521 & after)	835019
	- Wide 79"	290710	43	Ballast Assy., Marketing, 230V	290901
	- Narrow	289710	44	Port W/A, Marketing	290540
15	Nyliner	916012		Anti-Theft Plate, Marketing, with EMS Motion Sensor	291589
16	Top Hinge, Left, Marketing	810057	45	- without EMS Motion Sensor	290519
17	Carriage Bolt	901008		T-Handle Assy, Marketing	812271
18	Top Hinge Spacer	010016		- 1504 & after	812290
19	Temperature Sensor, Marketing	822041	46	Select Button, Marketing	815272
20	Lamp Bracket (Top) Marketing	290533	47	Water Diverter, Marketing	290574
21	Control Board Mounting Panel	290523	48	Burst Open Latch Strike Assy, Marketing	290546
22	Cabinet Assembly 72", Wide Marketing	291020	49	Rain Guard, Wide Marketing	290592
	- 79" Wide, Marketing	290020	50	Left Vandal Panel 79", Marketing	290003
23	Transformer, Standard 230 VAC	842220		- 72", Marketing	291003
	- Australia / NZ / N. Ireland	842221		- 79", UHR	141022
24	Rod Retainer, Wide	281709		- 72", UHR	142022
	- Narrow	283704	51	Right Vandal Panel 79" Marketing	290585
25	Water Diverter (Top Hinge) Marketing	290575		- 72", Marketing	291585
26	Main Door Bottom Hinge, Marketing	290010	52	Cable Clamp	916004
27	Flat Washer	904002	53	Ballast Panel, Marketing	290531
28	Keps Nut 3/8-16	905007	54	Ballast Panel Brace, Marketing	290532
29	Latch Strike Assembly	010030		-Narrow	292505
30	Bracket, Chute Locator	095002	55	Port Brace, Marketing	290521
31	Can Chute Tie Bracket	010017	56	IEC Interrupt Switch	835015
32	Control Board	836115	•	Ballast Panel Assy., Marketing	290571
33	Fuse Box Bracket IEC	010087			
	- Fuse Box Assembly	842219			

\*Except 72" Marketing Venders, which start PO 1528 and after.

# SECTION 7: EXPLODED VIEWS

## Coca-Cola Marketing Vender

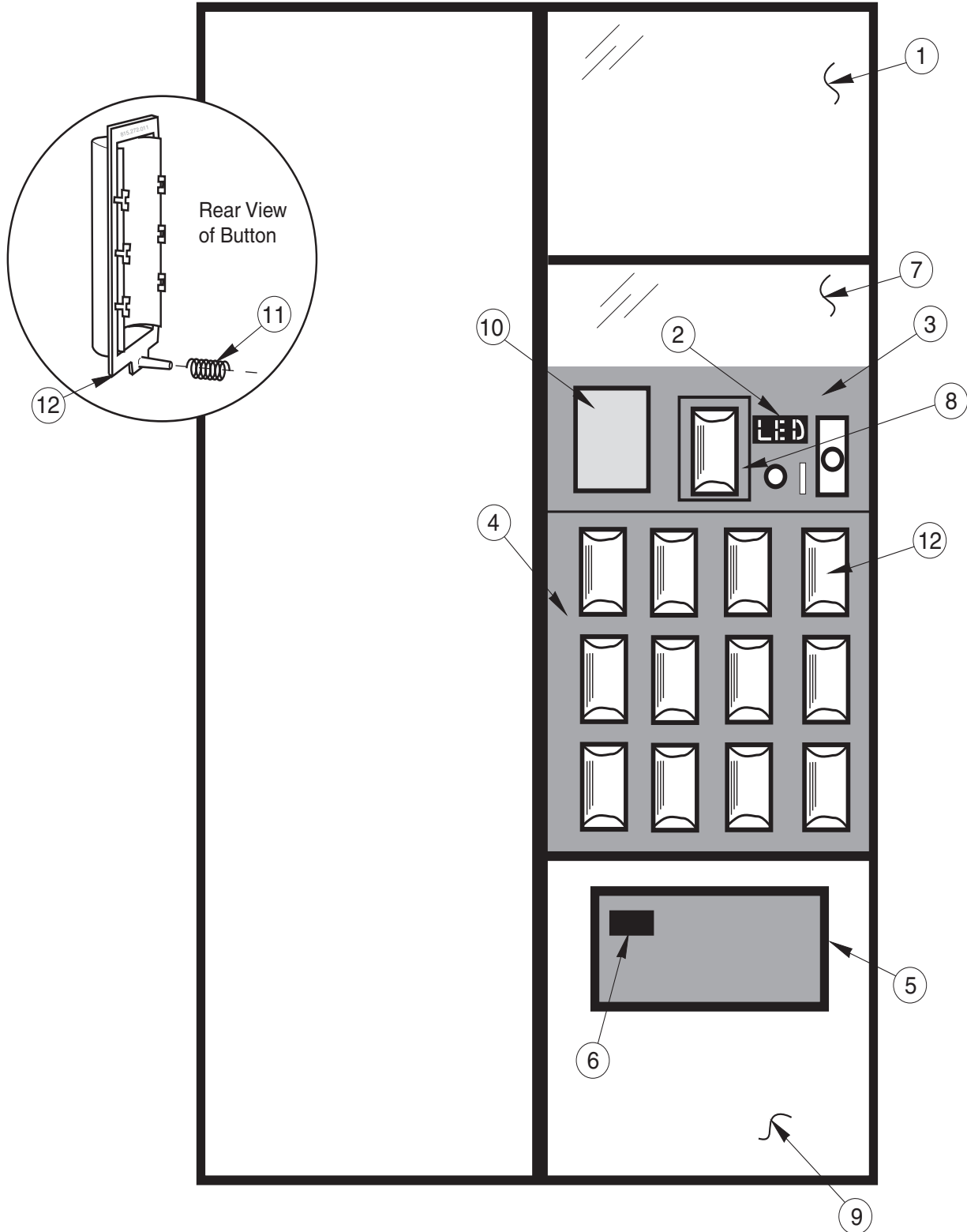

# SECTION 7: EXPLODED VIEWS

---

## Coca-Cola Marketing Vender

Item No.	Description	Part No.
1	Ad Panel, Lexan only, 79" Marketing .....	849166
	- 72" Marketing.....	848574
	• Ad panel card (behind Lexan), Can .....	831529
	- Can / Bottle.....	831530
	- Bottle .....	831531
2	L.E.D. Assembly .....	291525
3	Control Panel Assy, Marketing, 200307 and after.....	338565
	- 200306 and before .....	290599
4	Button Panel Assy. with Harness, Marketing, Wide .....	290566
	- Marketing, Narrow .....	292530
	- Button Panel Decal, 12 select .....	831516
	- Button Panel Decal, 8 select .....	831515
5	Port Trim, Marketing .....	290516
6	Coin Cup, Marketing .....	290522
7	Lexan POS Window, Marketing .....	815304
8	Feature Button Bracket, Marketing .....	290569
9	Port Panel Sign, Marketing, 200307 and after.....	849167
	- 200306 and before .....	848278
10	Banknote Acceptor Cover .....	291526
11	Spring .....	914004
12	Select Button .....	815272
•	Feature Button Bracket Decal.....	831349
•	Control Panel Decal, Marketing, 200307 and after.....	831512
	- 200306 and before .....	848233
•	Control Panel Decal, Marketing (with lock cover holes), 200307 and after .....	831511
	- 200306 and before .....	848295
•	Black Christmas Tree.....	916009
•	Red Christmas Tree.....	916084
•	Red Carriage Bolt .....	901051
•	Red Pop Rivet.....	908015

**Note:** Clip-On Trim started with P.O. 1529B and after.

# SECTION 7: EXPLODED VIEWS

## Rear Door Miscellaneous Assemblies

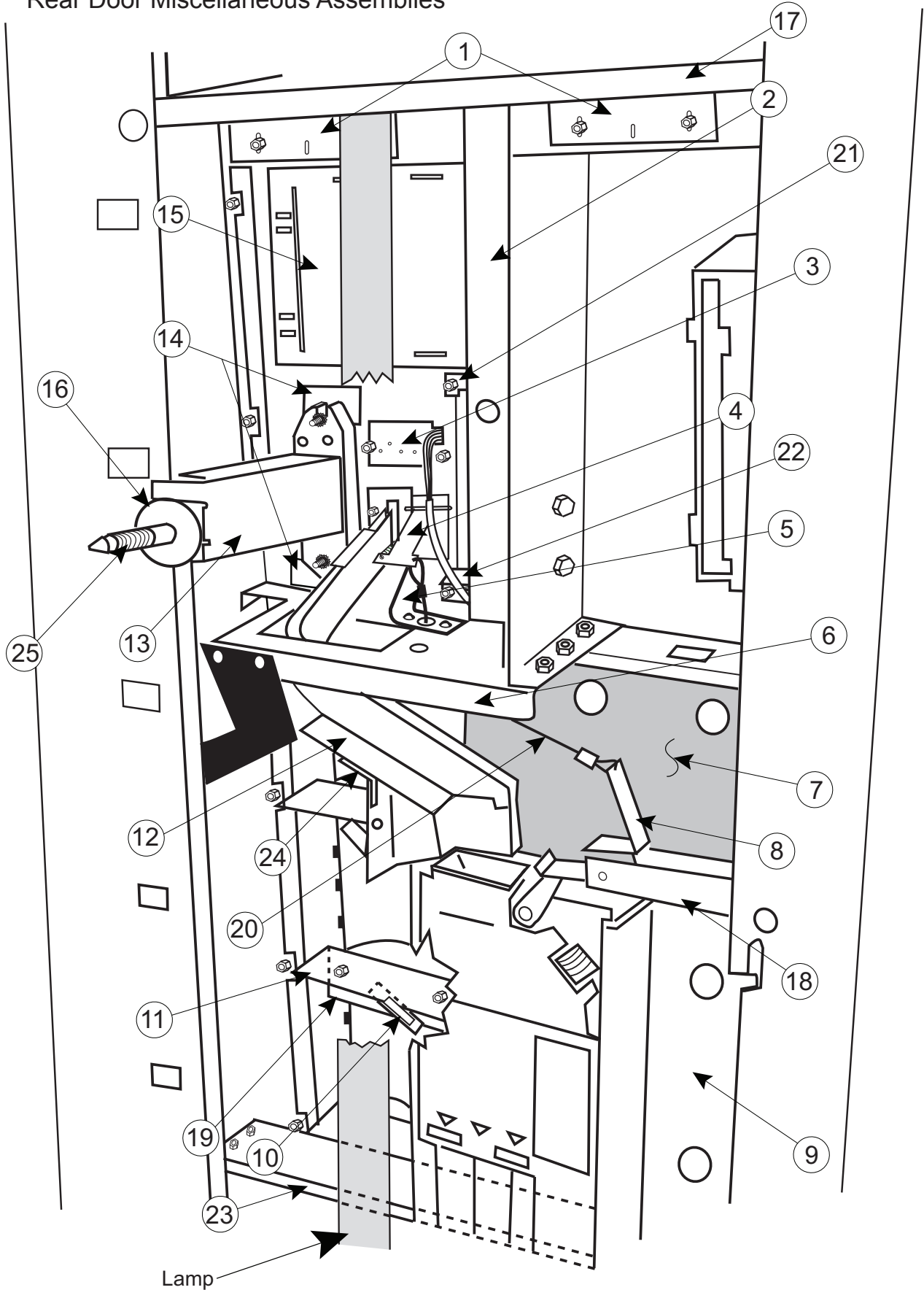



# SECTION 7: EXPLODED VIEWS

---

## Coca-Cola Marketing Vender Rear Door Miscellaneous Assemblies

Item No.	Description	Part No.
1	Control Panel Strap, Marketing.....	290582
2	Banknote Acceptor Divider, Marketing.....	290541
3	LED Assy, Marketing.....	291525
4	Coin Return Lever Assy, Marketing .....	291529
5	Lever Stop, Marketing.....	290544
6	Control Panel Brace, Marketing.....	290529
7	Changer Shield, Marketing .....	290525
8	Coin Return Hinge, Marketing .....	290543
9	Changer Door Assy, Marketing.....	290562
10	Select Switch .....	835001
11	Switch Carrier Strip, Marketing .....	815273
12	Coin Chute Assy, Marketing.....	290564
13	T-Handle Brace, Marketing.....	290539
14	Hole Block Cover, Marketing .....	290555
15	POS Window Plate, Marketing .....	290535
16	T-Stud Sealer Washer .....	915258
17	Bulkhead, Top .....	290515
18	Coin Return Hinge Bracket.....	290543
19	Button Channel, Marketing .....	290506
20	Cable .....	911032
21	Feature Button Bracket.....	290512
22	Feature Button Plate.....	290538
23	Bulkhead, Bottom .....	290514
24	Coin Chute Support .....	290542
25	T-Bolt .....	901052
•	Banknote Acceptor Guard, Marketing.....	290101
•	Painted Hole Block Cover .....	290108
•	LED Shroud, Marketing .....	929031
•	Select Button Spring, Marketing.....	914024

# SECTION 7: EXPLODED VIEWS

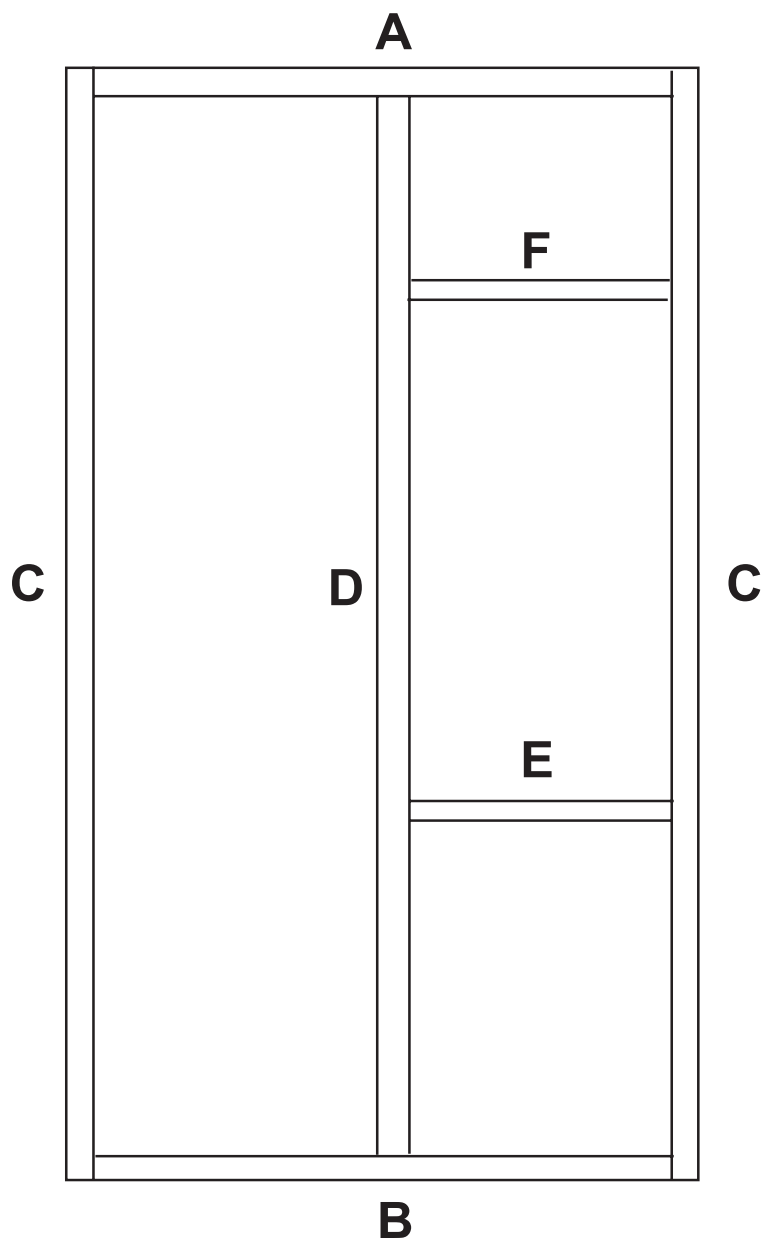

**Black Marketing  
“Clip-On” Trim**  
*(200307 & after)*

**Model 804 Marketing, Clip On (Kit # 338501)**

Item	Part Number	Length (cm)
A	339539	87.0
B	339538	87.0
C	338502	195.4
D	338503	188.0
E	339541	39.4
F	339545	39.4

**Model 550 Marketing Clip On (Kit # 341503)**

Item	Part Number	Length (cm)
A	341505	71.6
B	341504	71.6
C	339536	176.2
D	339537	168.8
E	339541	39.4
F	339545	39.4

**Model 660 Marketing, Clip On (Kit # 339535)**

Item	Part Number	Length (cm)
A	339539	87.0
B	339538	87.0
C	339536	176.2
D	339537	188.0
E	339541	39.4
F	339545	39.4

# SECTION 7: EXPLODED VIEWS

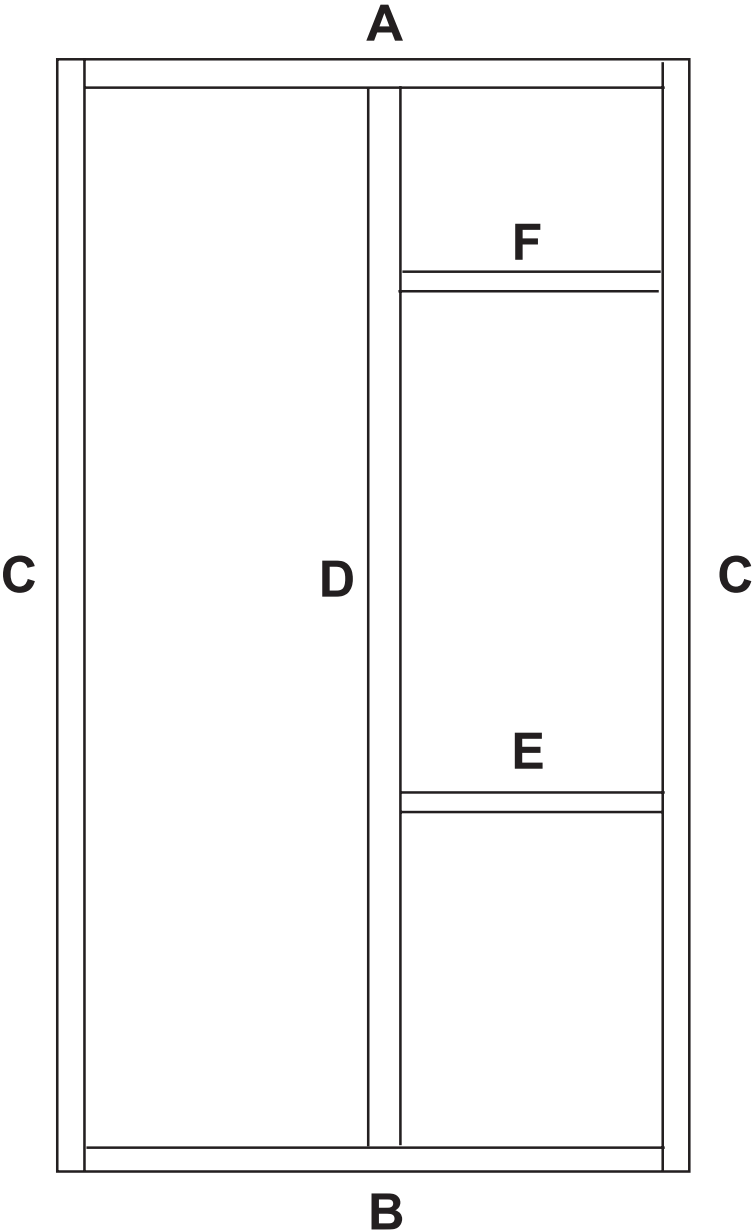

**Red Marketing  
“Clip-On” Trim**  
*(run 1522 and after)*

**Model 804 Marketing, Clip On (Kit # 294501)**

Item	Part Number	Length (cm)
A	291539	85.7
B	291538	85.7
C	292513	194.2
D	292514	186.8
E	291541	37.9
F	291545	37.9

**Model 550 Marketing Clip On (Kit # 293503)**

Item	Part Number	Length (cm)
A	292515	70.3
B	292515	70.3
C	291536	175.0
D	291537	167.6
E	291541	37.9
F	291545	37.9

**Model 660 Marketing, Clip On (Kit # 291535)**

Item	Part Number	Length (cm)
A	291539	85.7
B	291538	85.7
C	291536	175.0
D	291537	167.6
E	291541	37.9
F	291545	37.9

# SECTION 7: EXPLODED VIEWS

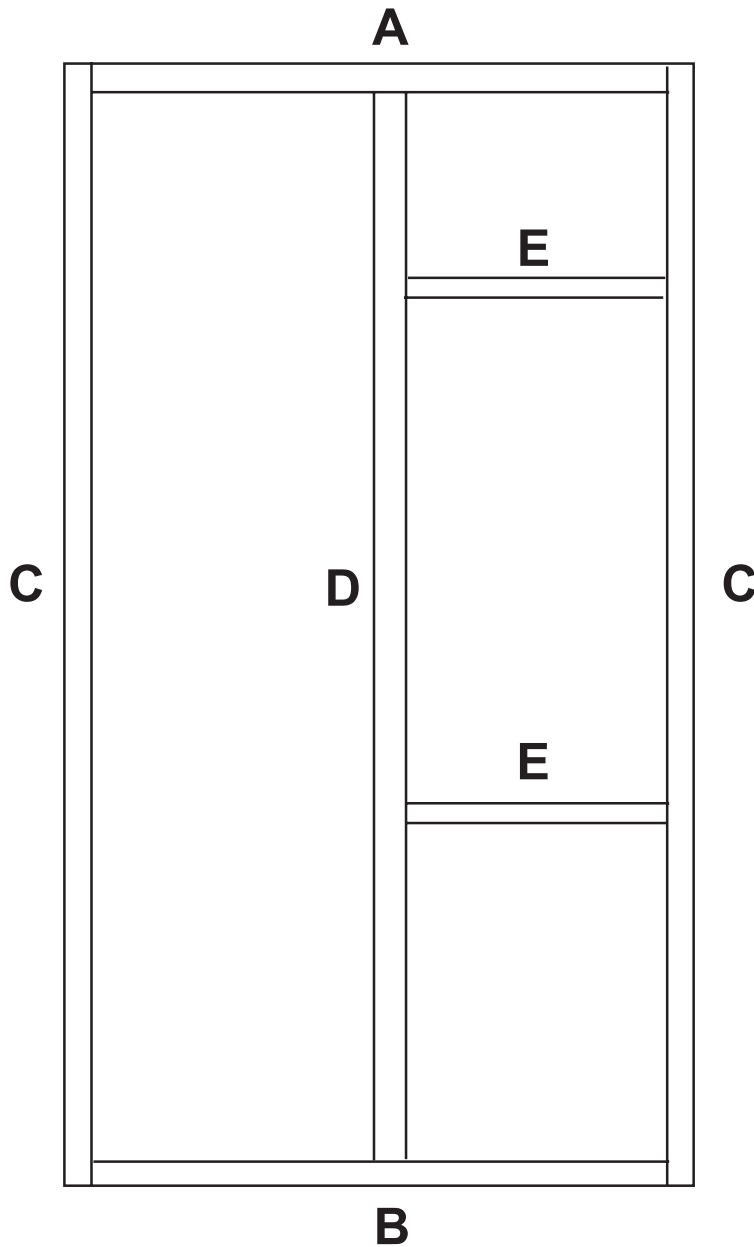

**Marketing Trim**  
*(prior to run 1522)*

**Model 804 Marketing (Kit # 290586)**

Item	Part Number	Length (cm)
A	290587	85.4
B	290588	85.4
C	290589	194.7
D	290596	187.2
E	290597	38.0

**Model 550 Marketing (Kit # 293502)**

Item	Part Number	Length (cm)
A	292508	70.0
B	292509	70.0
C	291508	175.5
D	291509	168.0
E	290597	38.0

**Model 660 Marketing (Kit # 291507)**

Item	Part Number	Length (cm)
A	290587	85.4
B	290588	85.4
C	291508	175.5
D	291509	175.5
E	290597	38.0

# SECTION 7: EXPLODED VIEWS

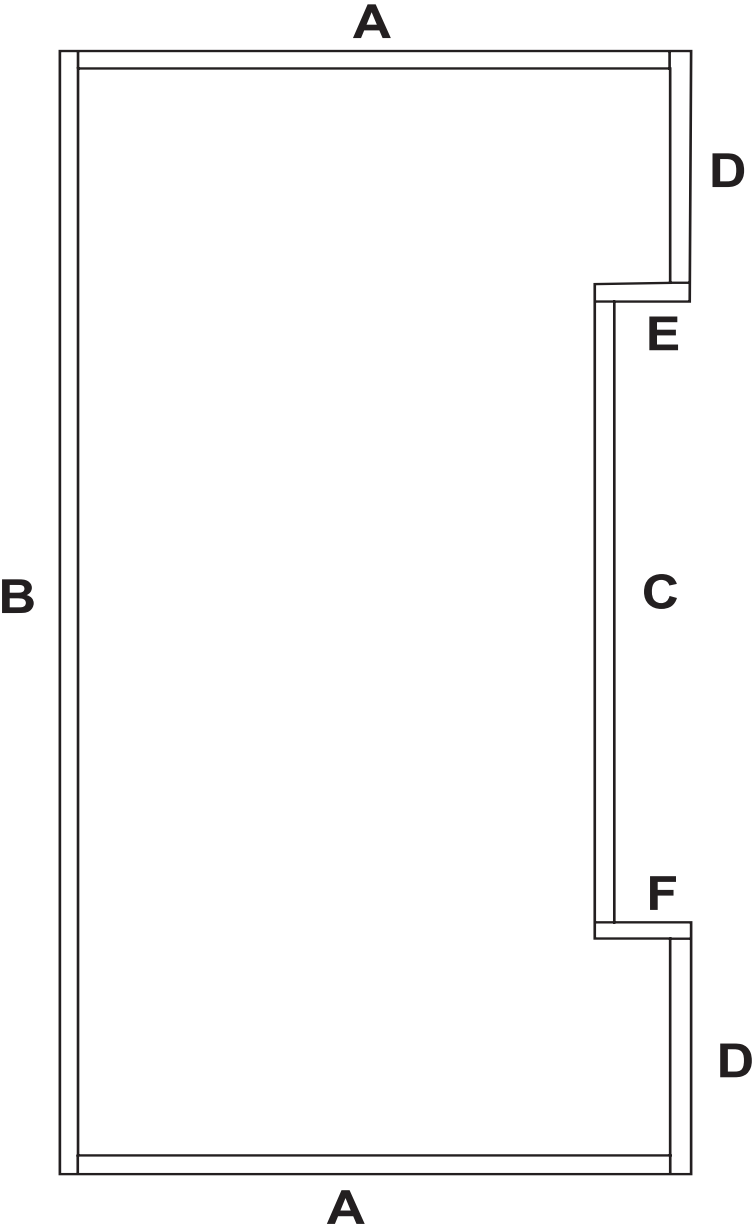

**Landscape Trim**  
*(run 1525 and after)*

**Model 804 Landscape (Kit # 143509)**

Item	Part Number	Length (cm)
A	141552	88.0
B	141553	193.7
C	143511	107.0
D	143512	40.6
E	815311	
F	815312	

**Model 550 Landscape (Kit # 259560)**

Item	Part Number	Length (cm)
A	258507	74.1
B	142502	174.6
C	143511	107.0
D	142508	31.1
E	815311	
F	815312	

**Model 660 Landscape (Kit # 142507)**

Item	Part Number	Length (cm)
A	141552	88.0
B	142502	174.6
C	143511	107.0
D	142508	31.1
E	815311	
F	815312	

# SECTION 7: EXPLODED VIEWS

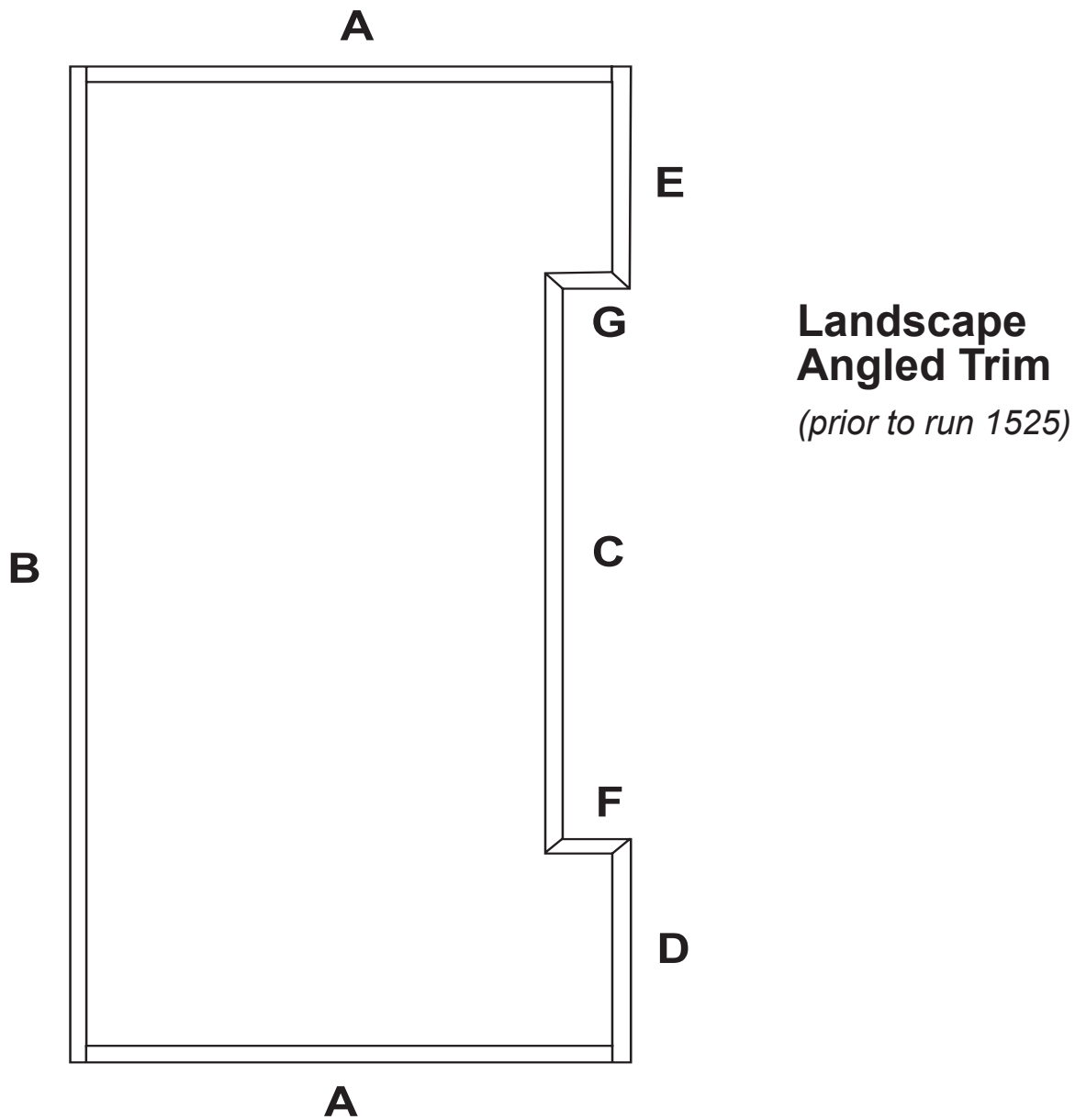

**Model 804 Landscape (Kit # 141590)**

Item	Part Number	Length (cm)
A	141552	88.0
B	141553	193.7
C	141556	112.7
D	141555	43.3
E	141554	43.3
F	141558	14.3
G	141557	14.3

**Model 550 Landscape (Kit # 259520)**

Item	Part Number	Length (cm)
A	258507	74.1
B	142502	174.6
C	141556	112.7
D	142504	34.0
E	142503	34.0
F	141558	14.3
G	141557	14.3

**Model 660 Landscape (Kit # 142530)**

Item	Part Number	Length (cm)
A	141552	88.0
B	142502	174.6
C	141556	112.7
D	142504	34.0
E	142503	34.0
F	141558	14.3
G	141557	14.3



## **CREDIT AND REPLACEMENT POLICY**

Credits or replacements will be issued on warranty items if the proper procedures are followed:

1. ROYAL VENDORS will pay shipping charges on all parts covered under this warranty when transport has been made the most economical way.
2. Credits will only be issued to warranty parts that have been ordered in advance, not for parts ordered as stock. (NO EXCEPTIONS)
3. When ordering warranty parts in advance, please have the full vender / unit serial number.
4. A copy of the Packing Slip, the correct serial number and complete Return Material Tag (provided with part) are required for sending back parts. Please fill out the Return Material Tag completely, keeping the white copy for your records and sending the yellow tag back with the attached part. Make sure you have your company name, address, telephone number, serial number, and model number, along with a brief explanation of the problem.
5. If the item returned is not under warranty, it will be sent back to you at your expense or it will be scrapped.
6. All warranty parts should be properly wrapped and packed securely to avoid further damage.
7. If parts are not returned within 15 working days, the invoice will be due in full.

